



Product Innovations

05/2021

2021 EN



ZCC Cutting Tools Europe GmbH

your Partner | your Value

The Company

Zhuzhou Cemented Carbide Cutting Tools Co., Ltd. (ZCC-CT) is located in Zhuzhou, Hunan in the People's Republic of China is the largest Chinese manufacturer of carbide tools. ZCC-CT belongs to the Zhuzhou Cemented Carbide Group (ZCC), which manufactures carbide products and carbide powders. Both companies are part of the Minmetals Corporation, which Trades in mining metals and minerals.

Since its founding in 1953, ZCC Cutting Tools has become one of the world's leading carbide manufacturers and has more than 2,000 employees, thanks to its highly qualified staff and use of the latest technologies. As a Minmetals Corporation company, ZCC-CT can completely cover the entire value-added chain of modern carbide tool production from the extraction of raw materials to the coated final product and all the steps in between.

Based on the latest European production technologies, it is possible for us to offer products with a consistent high quality at all times. The extensive product range includes carbide indexable inserts, indexable inserts made from cermet, CBN, PKD and ceramic, solid carbide tools as well as turning tool holders and suitable tool systems. The products are produced in accordance with the current international standards, such as ISO, DIN, ANSI, JIS and BSI. In addition, ZCC Cutting Tools offer customer-specific solutions and special carbide products in accordance with specifications.

Research and development are a very high priority at ZCC-CT. In this area ZCC-CT use the world's most modern equipment and advanced machinery from Germany and Switzerland, for which the investments are higher than average. With highly trained engineers and a qualified international team, ZCC Cutting Tools researches the necessary foundations and is constantly developing new and improved products based on them. The company continuously strives to improve quality in order to meet customers' growing demands for new and innovative products and to be able to individually enhance customer benefits.

Both production and administration in China are subject to the ISO 9001:2008 standard. Environmental management is subject to the ISO 14001:2004 standard.

Since 2003, ZCC Cutting Tools has had a branch office in Europe.

The European head office and central warehouse are located in Düsseldorf, Germany. All European countries as well as Russia and Turkey are serviced from there. The company's quality management system is certified in the area of sales and logistics of tools for metal processing in accordance with DIN EN ISO 9001:2008.

In order to meet our own high requirements for above-average customer service and in parallel with the growth of the company as a whole, the number of employees at ZCC Cutting Tools is growing in sales and internal sales, in technical support and application technology, research and development as well as in the areas of logistic, marketing, IT, human resources and accounting.

Our sales representatives and our sales partners in Europe together serve customers on site. ZCC-CT application engineers are furthermore available with all their expertise and experience by phone, email or personally in your production environment.

The internal sales team handles enquiries throughout Europe with native speakers and ensures together with the employees in logistics that all orders are delivered to you and all our customers as fast as possible.

All of us at ZCC Cutting Tools Europe are here for you and will support you as your competent partner in all questions of machining production. That is our definition of added value through partnership.

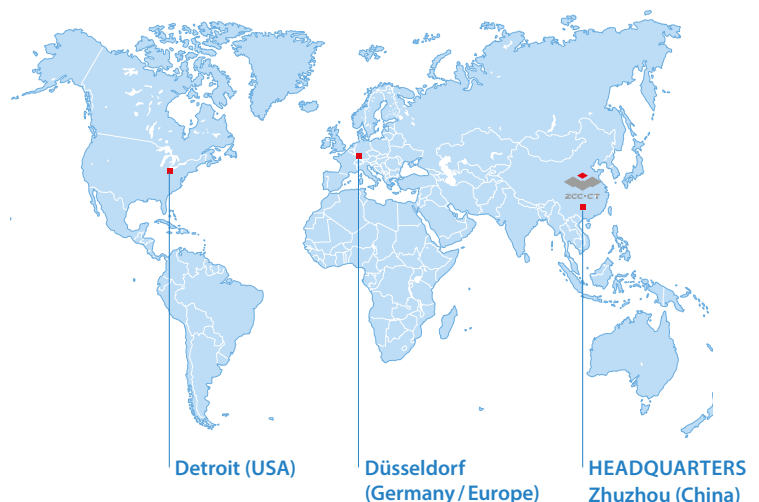

ZCC Cutting Tools Europe Your Machining Equipment Partner

New website

Many ways to find the precision tool you need

ZCC Cutting Tools Europe designed and launched a new website in under one year to give users multiple options to find the right precision tool for their individual application. The website provides interesting facts and information on applications, materials, tools, industry solutions, services and our company.

Expert knowledge and tool recommendations

Users can find information on tool recommendations on the Applications, Materials and Industry Solutions pages. If you want to know what general turning is, what the specific challenges of working with steel are or what the latest trends in the automotive sector are, the expert team at ZCC Cutting Tools can provide the answers you need and give targeted support in helping you find the right tool for you. And if you already know what category of tool you are looking for, all you need to do is click Tools in the navigation bar at the top of the screen to view the selected product line.

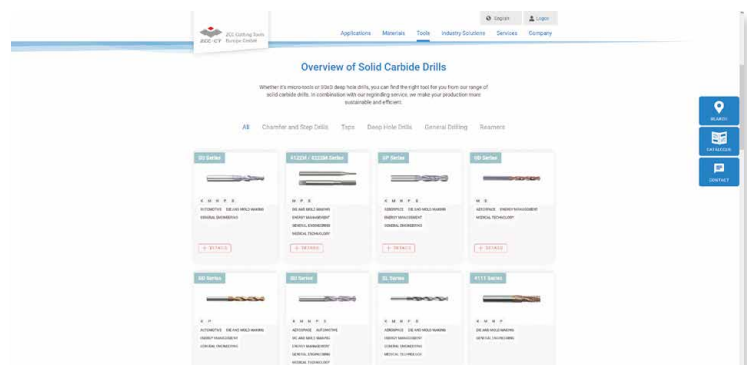

Overview of solid carbide drills



Tool overview lists possible applications

Users are always shown a list of recommended tools at the end of the process. In a simple table, the tool overview lists the precision tool along with the ISO material group and industry it is suitable for. You can also find a link to the comprehensive, full-length catalogue in the tool's detailed view. Along with that, registered customers can use the online ordering system to order the tool. For added convenience, an online order form will be integrated in the Special Tools page; this option should be available in May.

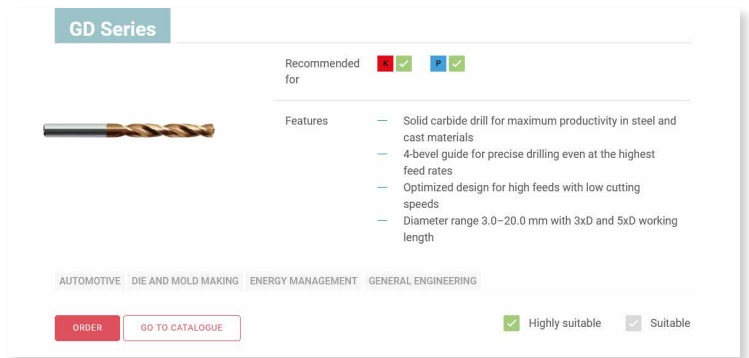

GD Series

Recommended for

Features

- Solid carbide drill for maximum productivity in steel and cast materials
- 4-bevel guide for precise drilling even at the highest feed rates
- Optimized design for high feeds with low cutting speeds
- Diameter range 3.0–20.0 mm with 3xD and 5xD working length

AUTOMOTIVE | DIE AND MOLD MAKING | ENERGY MANAGEMENT | GENERAL ENGINEERING

ORDER GO TO CATALOGUE Highly suitable Suitable

[Detailed view: GD series](#)



Dennis H., Product Manager Solid Carbide Tools

Focus on customer service

ZCC Cutting Tools offers customers a wide range of services. This includes our in-house test and demonstration centre, a regrinding service, customer training as well as a distribution partner search. The company is singularly focused on delivering high-quality service. Click Contact to find the ZCC staff member who can assist you with more information about the tool or service on the current page. This blue button can be found in the quick navigation bar on every page on the website

See Company History, Resources, Locations, Careers, Contact Us, Events & Exhibitions and News under Company for important news and information about ZCC Cutting Tools.

Visit our new website to find the matching precision tool for your specific application, or contact our team of experts who'll assist you in making your choice.

www.zccct-europe.com

Modular grooving system

Advantages of system and mechanical design	A6–A7
Tool orientation	A8
VDI – B1 and B4	A9
VDI – B2 and B3	A10
VDI – C1 and C4	A11
HSK-A	A12
PSC	A13
Base cartridge	A14
Primary cartridge	A15
Inserts	A16–A18



A

Turning

B

Milling

C

Drilling

D

Technical
Information

E

Index



Modular grooving system

Advantages of system and mechanical design

The tool holder is compatible with all primary cartridges, meaning it can be used in any grooving operation

Interlocking system ensures the tool holder and cartridge fit together seamlessly

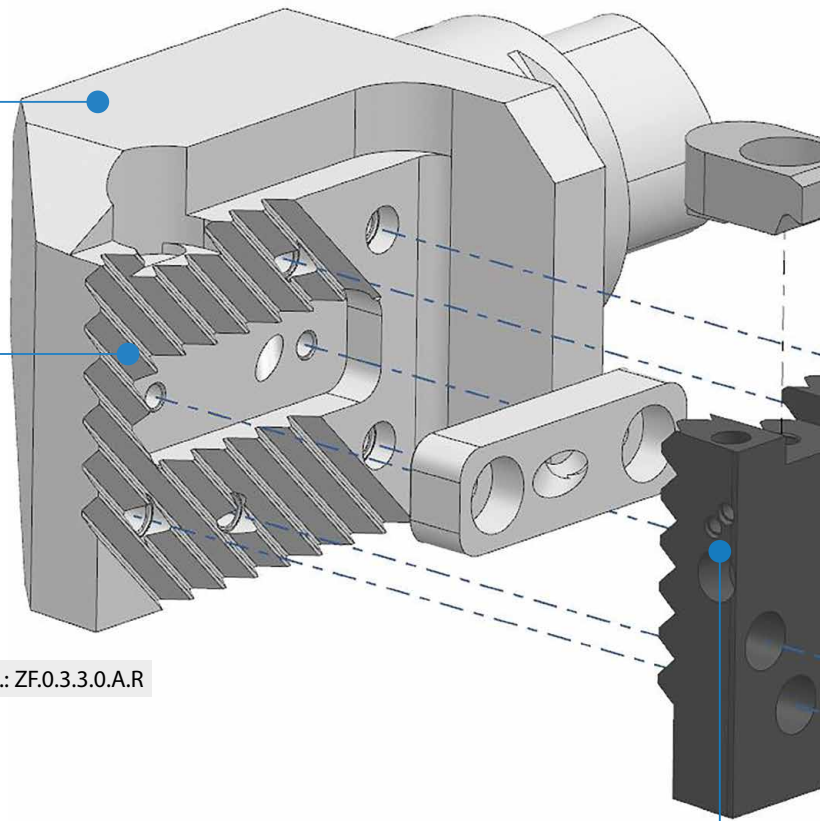
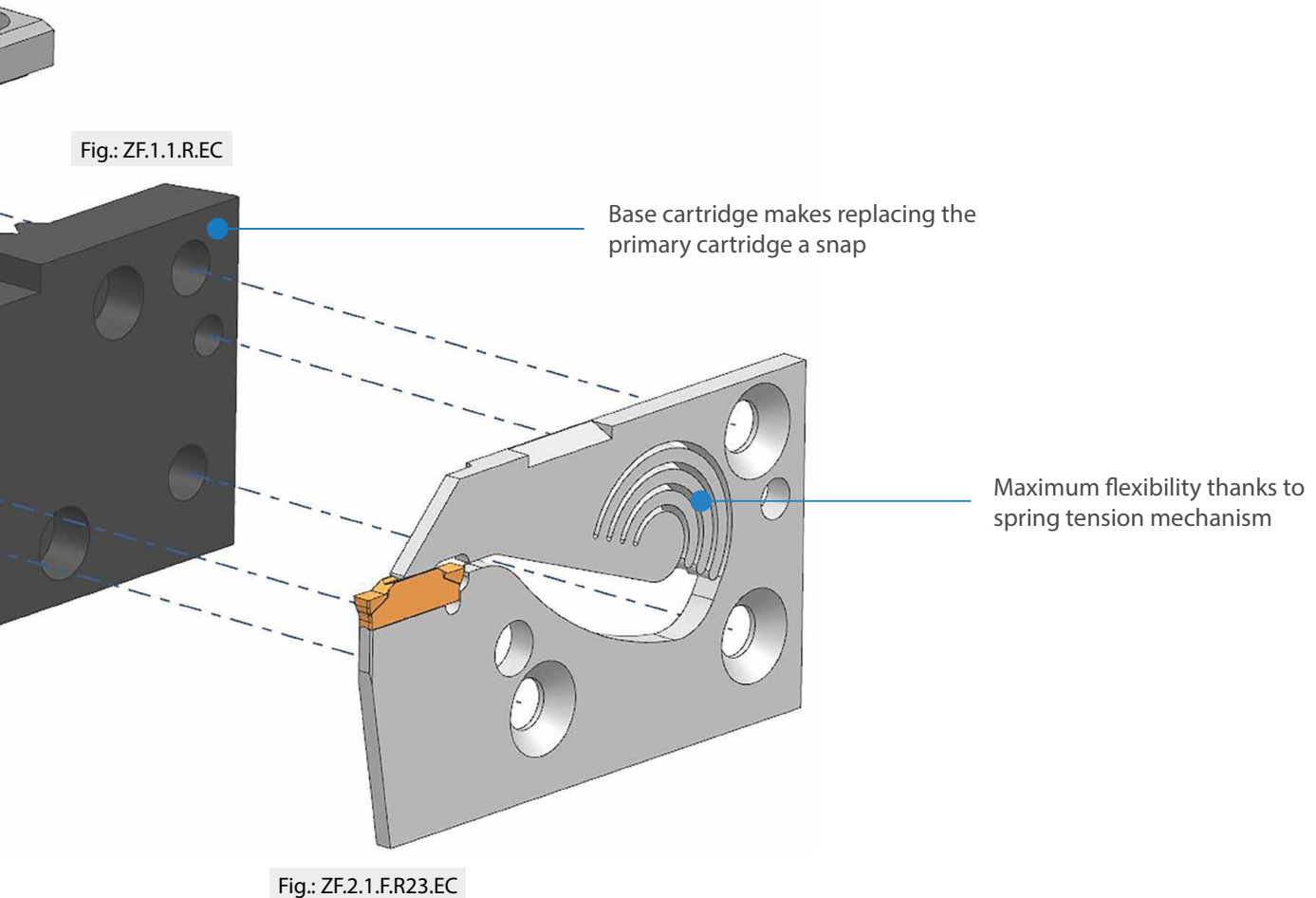

Fig.: ZF.0.3.3.0.A.R

ELI (External Like Internal)
coolant supply system

YOUR BENEFITS

- Gain flexibility and save time in production
- Only one tool holder needed which keep costs down
- Minimal wear and tear on spare parts thanks to rugged design of tool system
- ELI coolant supply as an low-cost alternative to internal cooling
- Clamping function with no plastic deformation



Tool orientation

VDI base adapter

Radial tool orientation if spindle rotates **left**

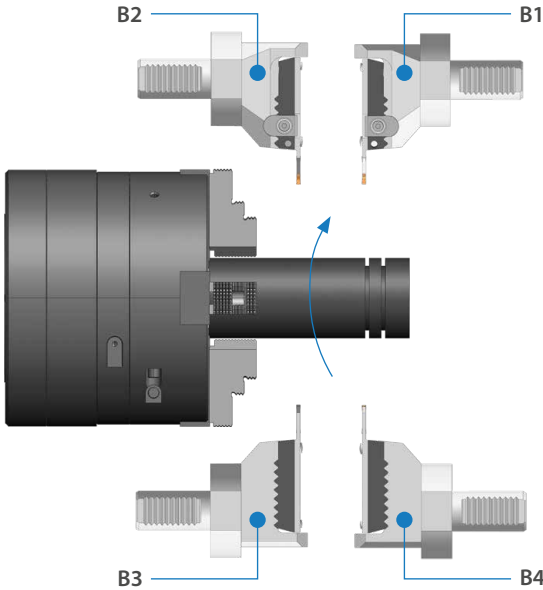

Radial tool orientation if spindle rotates **right**

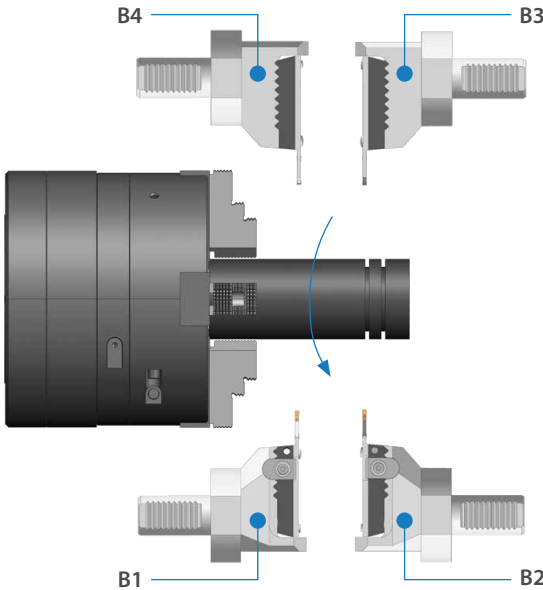

Tool holder VDI – B1 and B4

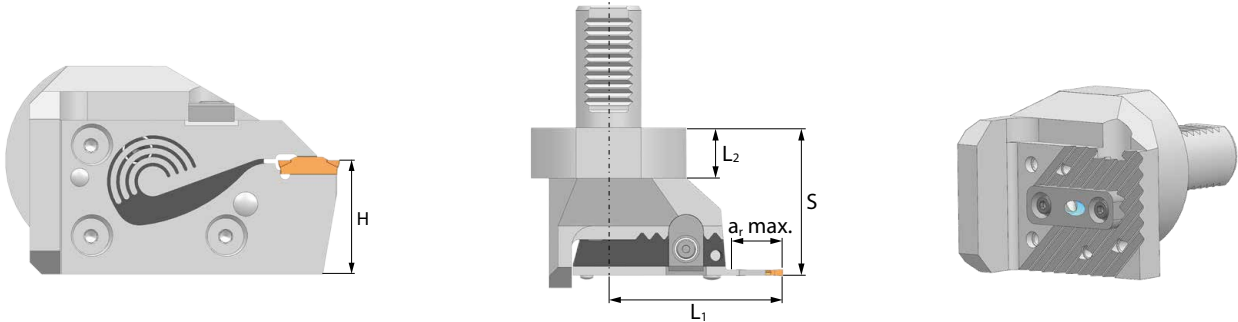

Article	VDI	Stock	Tool arrangement	Dimensions [mm]		Base cartridge
				L ₂		
ZF.0.1.1.1.A	VDI25	●	B1 and B4	18		ZF.1.1.L.**
ZF.0.1.2.1.A	VDI30	●	B1 and B4	22		ZF.1.1.L.**
ZF.0.1.3.1.A	VDI40	●	B1 and B4	22		ZF.1.1.L.**
ZF.0.1.4.1.A	VDI50	●	B1 and B4	30		ZF.1.1.L.**

● Ex stock ○ On demand

Primary cartridge

Article	*	Stock	Dimensions [mm]				
			W	H	L ₁	S	ar max.
ZF.2.1.A.L17.EC	ext.	●	1,5	37,4	71	67,3	17
ZF.2.1.B.L17.EC	ext.	●	2,0	37,4	71	67,5	17
ZF.2.1.E.L23.EC	ext.	●	2,5	37,4	77	67,6	23
ZF.2.1.F.L23.EC	ext.	●	3,0	37,4	77	67,6	23
ZF.2.1.G.L27.EC	ext.	●	4,0	37,4	81	67	27
ZF.2.1.H.L27.EC	ext.	●	5,0	37,4	81	68	27
ZF.2.1.K.L27.EC	ext.	●	6,0	37,4	81	69	27
ZF.2.1.L.L31.EC	ext.	●	8,0	37,4	85	70,5	31

● Ex stock ○ On demand

→ see A15 for dimensions of primary cartridge

Spare parts

	Article	Stock
	ZF.0.C.0	●

A

Turning

B

Milling

C

Drilling

D

Technical Information

E

Index

Tool holder VDI – B2 and B3

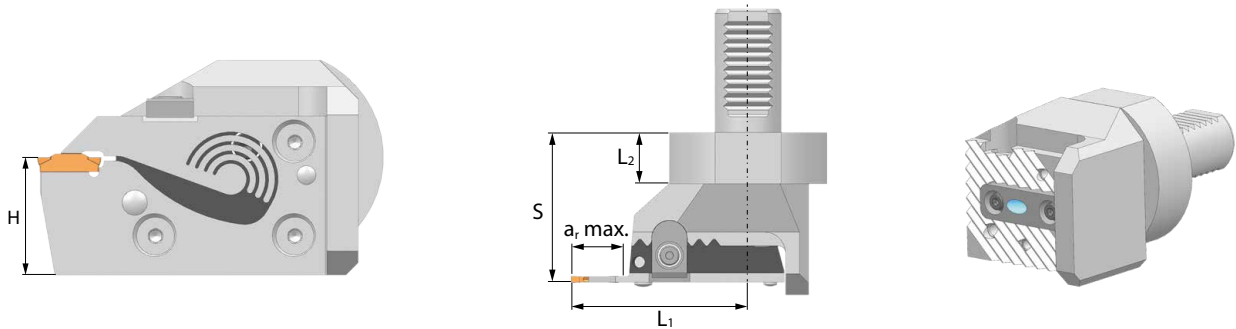

Article	VDI	Stock	Tool arrangement	Dimensions [mm]		Base cartridge
				L ₂		
ZF.0.1.1.2.A	VDI25	○	B2 and B3	18		ZF.1.1.R.**
ZF.0.1.2.2.A	VDI30	○	B2 and B3	22		ZF.1.1.R.**
ZF.0.1.3.2.A	VDI40	○	B2 and B3	22		ZF.1.1.R.**
ZF.0.1.4.2.A	VDI50	○	B2 and B3	30		ZF.1.1.R.**

● Ex stock ○ On demand

Primary cartridge

Article	*	Stock	Dimensions [mm]				
			W	H	L ₁	S	a _r max.
ZF.2.1.A.R17.EC	ext.	●	1,5	37,4	71	67,3	17
ZF.2.1.B.R17.EC	ext.	●	2,0	37,4	71	67,5	17
ZF.2.1.E.R23.EC	ext.	●	2,5	37,4	77	67,6	23
ZF.2.1.F.R23.EC	ext.	●	3,0	37,4	77	67,6	23
ZF.2.1.G.R27.EC	ext.	●	4,0	37,4	81	67	27
ZF.2.1.H.R27.EC	ext.	●	5,0	37,4	81	68	27
ZF.2.1.K.R27.EC	ext.	●	6,0	37,4	81	69	27
ZF.2.1.L.R31.EC	ext.	●	8,0	37,4	85	70,5	31

● Ex stock ○ On demand

→ see A15 for dimensions of primary cartridge

Spare parts

	Article	Stock
	Clamp ZF.0.C.0	●

Tool holder VDI – C1 and C4

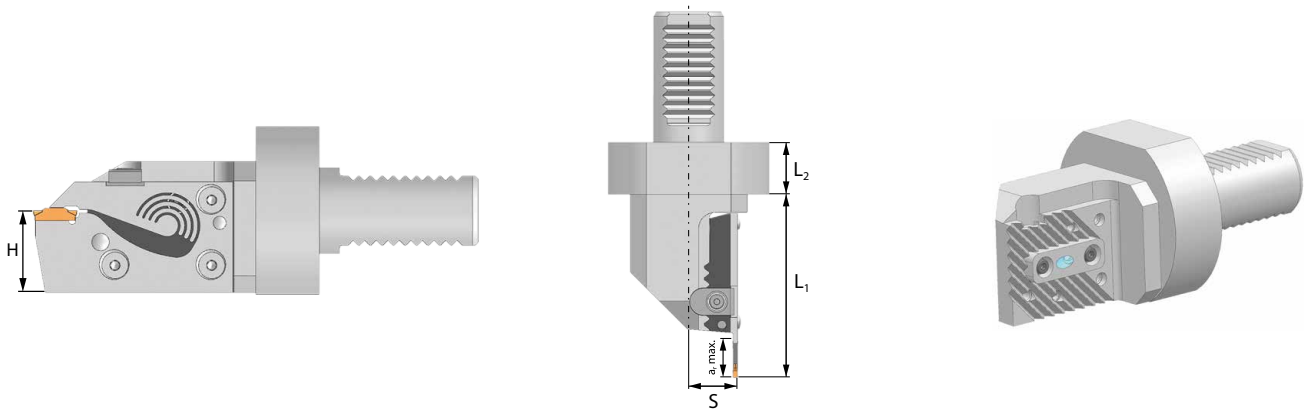

Article	VDI	Stock	Tool arrangement	Dimensions [mm]		Base cartridge
				L ₂		
ZF.0.1.1.3.A	VDI25	●	C1 and C4	18		ZF.1.1.R.**
ZF.0.1.2.3.A	VDI30	●	C1 and C4	22		ZF.1.1.R.**
ZF.0.1.3.3.A	VDI40	●	C1 and C4	22		ZF.1.1.R.**
ZF.0.1.4.3.A	VDI50	●	C1 and C4	30		ZF.1.1.R.**

● Ex stock ○ On demand

Primary cartridge

Article	*	Stock	Dimensions [mm]				
			W	H	L ₁	S	a _r max.
ZF.2.1.A.R17.EC	ext.	●	1,5	37,4	96	27,0	17
ZF.2.1.B.R17.EC	ext.	●	2,0	37,4	96	27,2	17
ZF.2.1.E.R23.EC	ext.	●	2,5	37,4	102	27,3	23
ZF.2.1.F.R23.EC	ext.	●	3,0	37,4	102	27,3	23
ZF.2.1.G.R27.EC	ext.	●	4,0	37,4	106	26,7	27
ZF.2.1.H.R27.EC	ext.	●	5,0	37,4	106	27,7	27
ZF.2.1.K.R27.EC	ext.	●	6,0	37,4	106	28,7	27
ZF.2.1.L.R31.EC	ext.	●	8,0	37,4	110	30,2	31

● Ex stock ○ On demand

→ see A15 for dimensions of primary cartridge

Spare parts

	Article	Stock
	Clamp ZF.0.C.0	●

A

Turning

B

Milling

C

Drilling

D

Technical Information

E

Index

Tool holder HSK-A

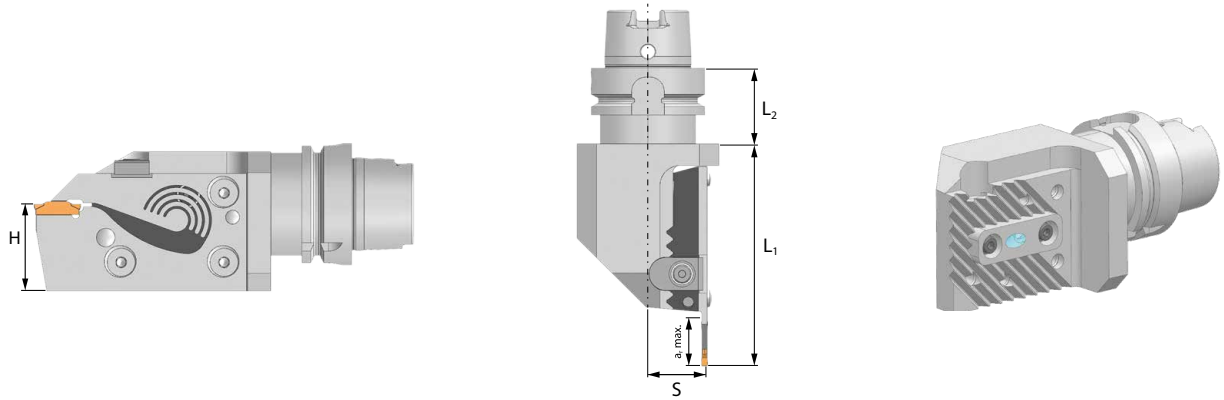

Article	HSK-A	Stock		Dimensions [mm]		Base cartridge
		R	L	L ₂		
ZF.0.2.1.0.A.R/L	HSK-A 32	○	○	36		ZF.1.1.R/L.**
ZF.0.2.2.0.A.R/L	HSK-A 40	●	●	36		ZF.1.1.R/L.**
ZF.0.2.3.0.A.R/L	HSK-A 63	●	●	42		ZF.1.1.R/L.**
ZF.0.2.4.0.A.R/L	HSK-A 80	○	○	42		ZF.1.1.R/L.**
ZF.0.2.5.0.A.R/L	HSK-A 100	○	○	45		ZF.1.1.R/L.**

● Ex stock ○ On demand

Primary cartridge

Article	*	Stock		Dimensions [mm]				
		R	L	W	H	L ₁	S	ar max.
ZF.2.1.A.R/L17.EC	ext.	●	●	1,5	37,4	96	27,0	17
ZF.2.1.B.R/L17.EC	ext.	●	●	2,0	37,4	96	27,2	17
ZF.2.1.E.R/L23.EC	ext.	●	●	2,5	37,4	102	27,3	23
ZF.2.1.F.R/L23.EC	ext.	●	●	3,0	37,4	102	27,3	23
ZF.2.1.G.R/L27.EC	ext.	●	●	4,0	37,4	106	26,7	27
ZF.2.1.H.R/L27.EC	ext.	●	●	5,0	37,4	106	27,7	27
ZF.2.1.K.R/L27.EC	ext.	●	●	6,0	37,4	106	28,7	27
ZF.2.1.L.R/L31.EC	ext.	●	●	8,0	37,4	110	30,2	31

● Ex stock ○ On demand

→ see A15 for dimensions of primary cartridge

Spare parts

	Article	Stock
	Clamp ZF.0.C.0	●

Tool holder PSC

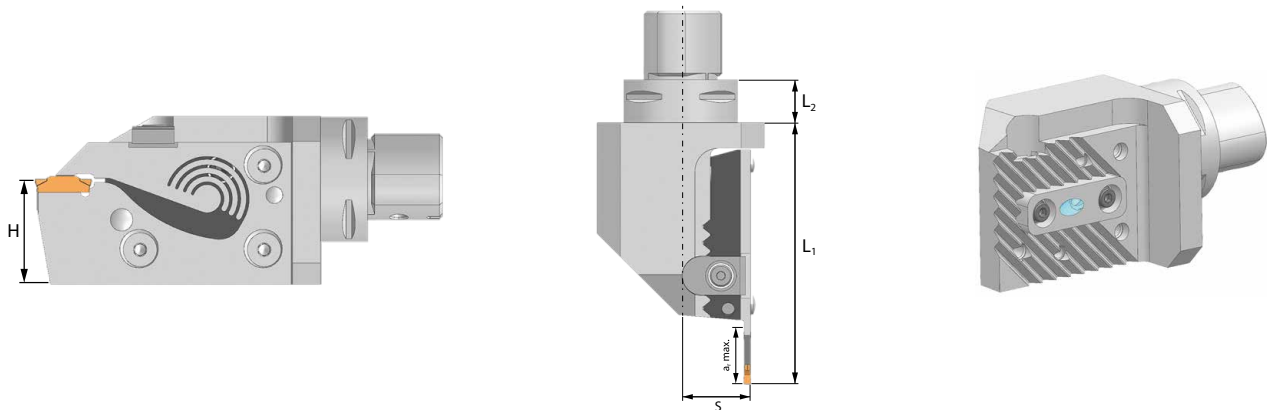

Article	PSC	Stock		Dimensions [mm]		Base cartridge
		R	L	L ₂		
ZF.0.3.1.0.A.R/L	PSC40	○	○	20		ZF.1.1.R/L.**
ZF.0.3.2.0.A.R/L	PSC50	●	●	20		ZF.1.1.R/L.**
ZF.0.3.3.0.A.R/L	PSC63	●	●	22		ZF.1.1.R/L.**
ZF.0.3.4.0.A.R/L	PSC80	○	○	30		ZF.1.1.R/L.**

● Ex stock ○ On demand

Primary cartridge

Article	*	Stock		Dimensions [mm]				
		R	L	W	H	L ₁	S	a _r max.
ZF.2.1.A.R/L17.EC	ext.	●	●	1,5	37,4	96	27,0	17
ZF.2.1.B.R/L17.EC	ext.	●	●	2,0	37,4	96	27,2	17
ZF.2.1.E.R/L23.EC	ext.	●	●	2,5	37,4	102	27,3	23
ZF.2.1.F.R/L23.EC	ext.	●	●	3,0	37,4	102	27,3	23
ZF.2.1.G.R/L27.EC	ext.	●	●	4,0	37,4	106	26,7	27
ZF.2.1.H.R/L27.EC	ext.	●	●	5,0	37,4	106	27,7	27
ZF.2.1.K.R/L27.EC	ext.	●	●	6,0	37,4	106	28,7	27
ZF.2.1.L.R/L31.EC	ext.	●	●	8,0	37,4	110	30,2	31

● Ex stock ○ On demand

→ see A15 for dimensions of primary cartridge

Spare parts

	Article	Stock
	Clamp ZF.0.C.0	●

A

Turning

B

Milling

C

Drilling

D

Technical Information

E

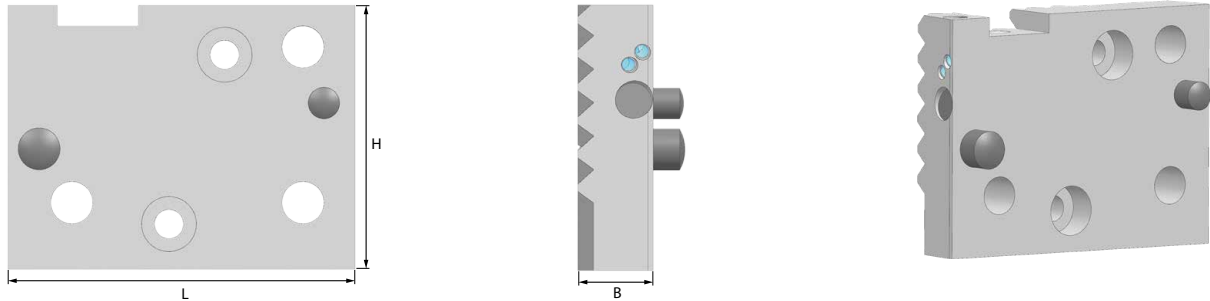

Index

Basic cartridge



Article	*	Stock		Dimensions [mm]		
		R	L	B	L	H
ZF.1.1.R/L.EC	ext.	●	●	11,25	66,5	50,5

● Ex stock ○ On demand

Spare parts			
		Article	Stock
	Screw	ZF.1.M5x25	●
	Seal	ZF.1.S.0	●
	Wrench	WH40L	●

A

Turning

B

Milling

C

Drilling

D

Technical Information

E

Index

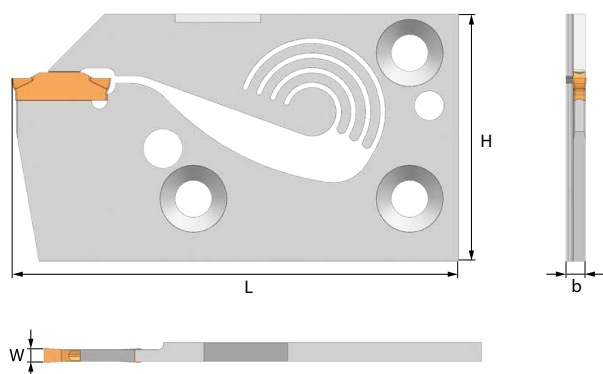

Primary cartridge



Article	*	Stock		Dimensions [mm]					Insert 
		R	L	W	H	a _r max.	L	b	
ZF.2.1.A.R/L17.EC	ext.	●	●	1,5	37,4	17	85,5	4,0	Z*AD01502
ZF.2.1.B.R/L17.EC	ext.	●	●	2,0	37,4	17	85,5	4,0	Z*BD02002
ZF.2.1.E.R/L23.EC	ext.	●	●	2,5	37,4	23	91,5	4,0	Z*ED02502
ZF.2.1.F.R/L23.EC	ext.	●	●	3,0	37,4	23	91,5	4,0	Z*FD0303
ZF.2.1.G.R/L27.EC	ext.	●	●	4,0	37,4	27	95,5	3,3	Z*GD0404
ZF.2.1.H.R/L27.EC	ext.	●	●	5,0	37,4	27	95,5	4,3	Z*HD0504
ZF.2.1.K.R/L27.EC	ext.	●	●	6,0	37,4	27	95,5	5,3	Z*KD0608
ZF.2.1.L.R/L31.EC	ext.	●	●	8,0	37,4	31	99,5	6,3	Z*LD0808

● Ex stock ○ On demand

Spare parts

		Article	Stock
	Screw	ZF.2.M6x28	●
	Wrench	WH40L	●

A

Turning

B

Milling

C

Drilling

D



Technical
Information

E











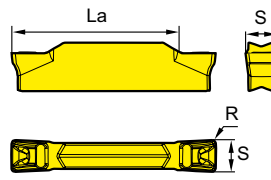

Index

A

Turning

-  Ideal machining conditions
-  Normal machining conditions
-  Unfavourable machining conditions

Parting inserts

Parting & grooving insert (double sided)						HC ¹ (CVD)	HC ¹ (PVD)	HW	
 <p>Double cutting edge</p>						P	   		
						M	   		
						K			
						N			
						S	  		
						H			
ISO	S	R±0.1	La max	f		YB9320 YBG205 YBG202 YBG302			
	ZTBD02002-MM	2,0	0,2	13	0,02-0,07		● ● ○ ○		
	ZTED02503-MM	2,5	0,3	17	0,03-0,1		●		
	ZTFD0303-MM	3,0	0,3	17	0,04-0,13		●		
	ZTGD0404-MM	4,0	0,4	22	0,06-0,18		●		
	ZTHD0504-MM	5,0	0,4	22	0,08-0,23		●		
	ZTKD0608-MM	6,0	0,8	22	0,12-0,27		●		
	ZTLD0808-MM	8,0	0,8	28	0,13-0,29		● ○		

● Ex stock ○ On demand



HC¹ Coated carbide
HW Uncoated carbide

B











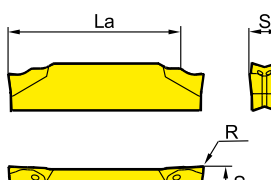







Milling

C

Drilling

-  Ideal machining conditions
-  Normal machining conditions
-  Unfavourable machining conditions

Parting inserts

Parting & grooving insert (double sided)						HC ¹ (CVD)	HC ¹ (PVD)	HW	
 <p>Double cutting edge</p>						P	 	  	
						M	  	  	
						K			
						N			
						S	 	 	
						H			
ISO	S±0.10	R±0.1	La max	f	YBC252 YBC251	YB9320 YBG202 YBG302	YD201		
	ZPED02502-MG	2,5	0,2	17	0,03-0,1	●	● ● ●		
	ZPFD0302-MG	3,0	0,2	17	0,04-0,13	●	● ● ●		
	ZPGD0402-MG	4,0	0,2	22	0,07-0,18	●	● ● ●	○	
	ZPHD0503-MG	5,0	0,3	22	0,1-0,24		● ● ●		
	ZPKD0604-MG	6,0	0,4	22	0,12-0,29	○	● ● ●		

● Ex stock ○ On demand

HC¹ Coated carbide
HW Uncoated carbide

D

Technical Information

E

Index

- Ideal machining conditions
- ⊗ Normal machining conditions
- ⊛ Unfavourable machining conditions

Parting inserts

Parting & grooving insert (double sided)								HC ¹ (CVD)	HC ¹ (PVD)	HW	
<p>R type</p>								P	⊗	⊗ ⊗ ⊗	
								M		⊗ ⊗ ⊗	
								K			
								N			
								S		⊗ ⊗	
								H			
ISO	L	S	θ	R	La max	f	YBC252	YB9320	YBG202 YBG302		
	ZPED02502-MG-6L	20,0	2,35	6°	0,2	17	0,03-0,08			○ ●	
	ZPED02502-MG-6R	20,0	2,35	6°	0,2	17	0,03-0,08		●	○ ●	
	ZPED02502-MG-15L	20,0	2,35	15°	0,2	17	0,03-0,05			○ ●	
	ZPED02502-MG-15R	20,0	2,35	15°	0,2	17	0,03-0,05			● ●	
	ZPFD0302-MG-6L	20,0	2,85	6°	0,2	17	0,04-0,1		●	● ●	
	ZPFD0302-MG-6R	20,0	2,85	6°	0,2	17	0,04-0,1		●	● ●	
	ZPFD0302-MG-15L	20,0	2,85	15°	0,2	17	0,04-0,08			● ●	
	ZPFD0302-MG-15R	20,0	2,85	15°	0,3	17	0,04-0,08	○	●	● ●	

● Ex stock ○ On demand

HC¹ Coated carbide
HW Uncoated carbide

Parting inserts

- Ideal machining conditions
- ⊗ Normal machining conditions
- ⊛ Unfavourable machining conditions

Parting & grooving insert (single sided)							HC ¹ (CVD)	HC ¹ (PVD)	HW	
<p>R type</p>							P		⊗	
							M		⊗	
							K			
							N			
							S		⊗	
							H			
ISO	L ±0.1	R ±0.1	S ±0.1	θ	f		YB9320			
	ZPES02502-MG-6L NEW!	19,9	0,2	2,5	6°	0,03-0,08		○		
	ZPES02502-MG-6R NEW!	19,9	0,2	2,5	6°	0,03-0,08		○		
	ZPFS0302-MG-6L NEW!	19,9	0,2	3	6°	0,04-0,1		○		
	ZPFS0302-MG-6R NEW!	19,9	0,2	3	6°	0,04-0,1		○		

● Ex stock ○ On demand

HC¹ Coated carbide
HW Uncoated carbide

A

Turning

B

Milling

C

Drilling

D



Technical Information

E











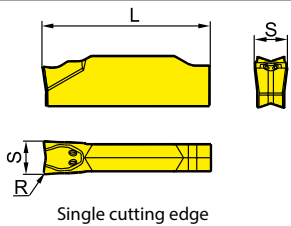

















Index

A

Turning

-  Ideal machining conditions
-  Normal machining conditions
-  Unfavourable machining conditions

Parting inserts

Parting & grooving insert (single sided)						HC ¹ (CVD)	HC ¹ (PVD)	HW	
 <p>Single cutting edge</p>						P		  	
						M		  	
						K			
						N			
						S		 	
						H			
ISO	L±0.1	R±0.1	S±0.10	f	YBC251	YB9320	YBG202 YBG302	YD201	
	ZPES02502-MG	19,9	0,2	2,5	0,03-0,1		 		
	ZPFS0302-MG	19,9	0,2	3	0,04-0,13		 		
	ZPGS0402-MG	19,9	0,2	4	0,07-0,18		 		
	ZPGS0402-MG-25 NEW!	24,6	0,2	4	0,07-0,18				
	ZPHS0503-MG	19,9	0,3	5	0,1-0,24		 		
	ZPHS0503-MG-25 NEW!	24,6	0,3	5	0,1-0,24				
	ZPKS0604-MG	19,9	0,4	6	0,12-0,29		 		
	ZPKS0604-MG-25 NEW!	24,6	0,4	6	0,12-0,29				

● Ex stock ○ On demand

HC¹ Coated carbide
HW Uncoated carbide

B

Milling

C



Drilling

D









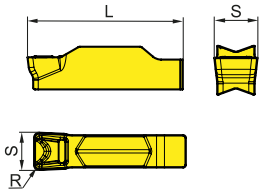

Technical Information

E

Index

-  Ideal machining conditions
-  Normal machining conditions
-  Unfavourable machining conditions

Parting inserts

Parting & grooving insert (single sided)						HC ¹ (CVD)	HC ¹ (PVD)	HW
						P		
						M		
						K		
						N		
						S		
						H		
ISO	L±0.1	R±0.1	S±0.10	f		YB9320		
	ZTES02503-MM NEW!	19,9	0,3	2,5	0,03-0,1			
	ZTFS0303-MM NEW!	19,9	0,3	3	0,04-0,13			
	ZTGS0404-MM-25 NEW!	24,6	0,4	4	0,06-0,18			
	ZTHS0504-MM-25 NEW!	24,6	0,4	5	0,08-0,23			
	ZTKS0608-MM-25 NEW!	24,6	0,8	6	0,12-0,27			

● Ex stock ○ On demand

HC¹ Coated carbide
HW Uncoated carbide



zFlex – Modular grooving system

Maintain flexibility in your production operations!

Indexable milling

System code – milling bodies	B22–B23
ISO-Code – inserts	B24–B25
FMA04 face milling system	B26–B29
FMWX face milling system	B30–B33
EMP09 Square shoulder mill with tangential inserts	B35–B36
Recommended cutting data	B38–B43

Solid carbide milling

System code – DIN-ISO series	B44
ALP/ALG series	B45–B55
Recommended cutting data	B56–B60

B

A

Turning

B

Milling

C

Drilling

D

Technical
Information

E

Index

FM A 12 050 – A22 O – N 06 – 04 (L) (C)

1 2 3 4 5 6 7 8 9 10 11

Type	
Code	Description
BM	Profile milling
CM	Chamfer milling
EM	Square shoulder milling
FM	Face milling
HM	Helical milling
SM	Slot milling
TM	T-slot milling
XM	Special

1

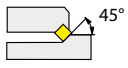
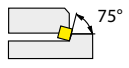
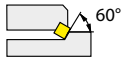
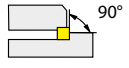
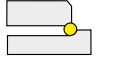
Entering angle			
A		E	
D		P	
R			

2

Serial number

3

Nominal diameter [mm]	
Code	Description
025	25
050	50
160	160
315	315
...	

4

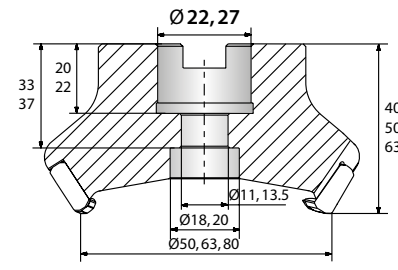
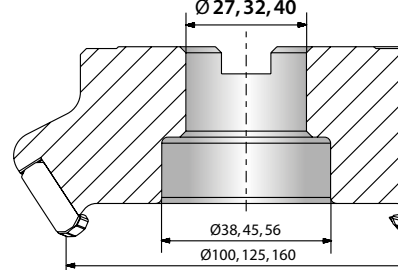
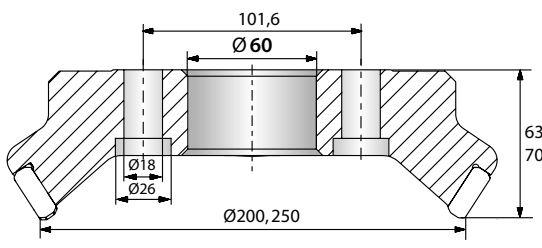
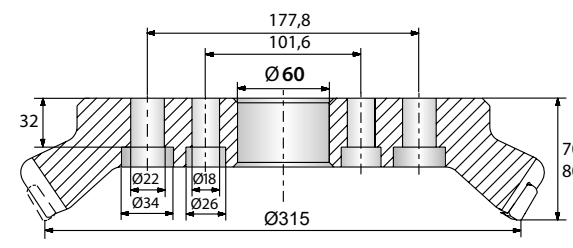
Type and size of tool holders			
Code	Type	Code	Type
A	Nominal diameter Ø50 – 80 mm	B	Nominal diameter Ø100 – 160 mm
			
C	Nominal diameter Ø200 – 250 mm	D	Nominal diameter Ø315 mm
			
G	Straight shank	XP	Weldon shank
K	Bore with keyway		

5

With respect to mounting please adhere to the information provided by the tool holder manufacturer.

Insert shape	
A	C
H	L
M	O
P	R
S	T
W	X Special
Z Special	

6

Clearance angle	
B	C
D	E
F	N
P	

7

Cutting edge length l [mm]	
Insert shape	
A	C, M
H, O, P	L
R	S
T	W

8

Number of teeth
9

9

Cutting direction	
Code	Description
L	Left

10

With inner cooling
11

11



Tools with B coupling and inner coolant supply require the following spare parts:



Coolant clamp screw



Coolant shower plate



Spare parts (B coupling with inner coolant supply)

		B27	B32	B40	B40
	∅	80	100	125	160
	Coolant clamp screw	LDB27C	LDB32C	LDB40C	LDB40C
	Coolant shower plate	B27-002-CP	B32-002-CP	B40-002-CP	B40-003-CP

When purchasing tools with inner coolant supply and B coupling these spare parts are included in delivery.

A

Turning

B

Milling

C

Drilling

D

Technical Information

E

Index

S P K N 12 04 ED T21K R – DM

1 2 3 4 5 6 7 8 9 10

A

Turning

B

Milling

C

Drilling

D

Technical Information

E

Index

Insert shape	
A	C
H	L
M	O
P	R
S	T
W	X Special
Z Special	

Clearance angle	
B	C
D	E
F	N
P	

Tolerance class			
Code	I.C [mm]	m [mm]	S [mm]
A	±0,025	±0,005	±0,025
C	±0,025	±0,013	±0,025
E	±0,025	±0,025	±0,025
F	±0,013	±0,005	±0,025
G	±0,025	±0,025	±0,130
H	±0,013	±0,013	±0,025
J	±0,05-0,13	±0,005	±0,025
K	±0,05-0,13	±0,013	±0,025
L	±0,05-0,13	±0,025	±0,025
M	±0,05-0,13	±0,08-0,18	±0,130
N	±0,05-0,13	±0,08-0,18	±0,025
U	±0,08-0,25	±0,13-0,38	±0,130

1

2

3

Fastening features (metric)	
Insert shape	
A	B
C	F
G	H
J	M
N	Q
R	T
U	W
X Special	

Cutting edge length l [mm]	
Insert shape	
A	C, M
H, O, P	L
R	S
T	W

4

5

Insert thickness S [mm]			
Code	S	Code	S
00	0,79	05	5,56
T0	0,99	T5	5,95
01	1,59	06	6,35
T1	1,98	T6	6,75
02	2,38	07	7,94
T2	2,58	09	9,52
03	3,18	T9	9,72
T3	3,97	11	11,11
04	4,76	12	12,70
T4	4,96		

6

Angle			
Code	Kr	Code	an
A	45°	A	3°
D	60°	B	5°
E	75°	C	7°
F	85°	D	15°
P	90°	E	20°
Z	Special	F	25°
		G	30°
		N	0°
		P	11°
		Z	Special

7

Chamfer							
Code	Type	Code	Angle	Code	Width [mm]	Code	Position
F		0	5°	0	0,10	K	
E		1	10°	1	0,15	P	
T		2	15°	2	0,20	W	
S		3	20°	3	0,25	-	
		4	25°	4	0,30		
		5	30°	5	0,35		
				6	0,40		
				7	0,45		

8

Cutting direction	
Code	Description
R	Right
L	Left
N	Right and left

9

Chip breaker overview
(starting on page B20 in the main catalogue, version 2019)

10

A

Turning

B

Milling

C

Drilling

D

Technical Information

E

Index

FMA04 face milling system

Ideal choice when working under unstable conditions or on thin components

YOUR BENEFITS

- 45° milling system with positive inserts generates low cutting forces
- Available for wide range of finishing and medium machining applications
- New insert design improves stability and ensures process reliability
- Highly economical due to eight-edged indexable insert

Precision insert seat enables high surface qualities

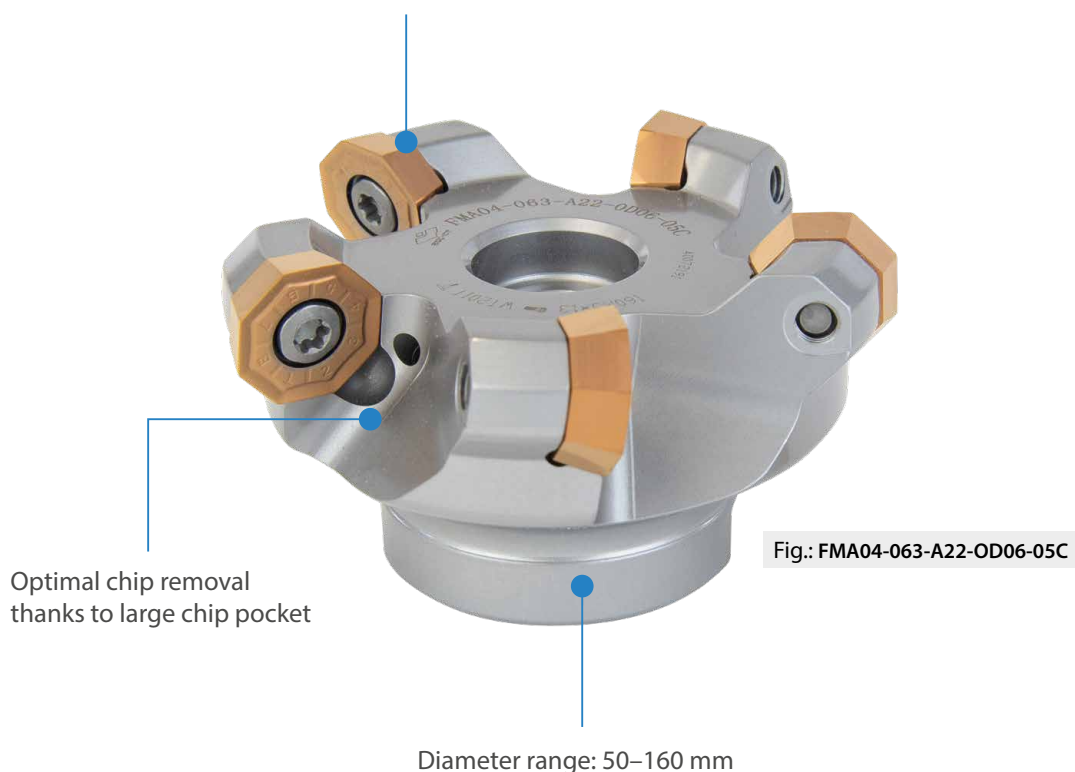

Insert grades

YBM253	YBG205	YB9320	YBD152	YBD252	YD101	YD201
CVD	PVD	PVD	CVD	CVD	-	-
P20-P40 M15-M35	P10-P30 M20-M40	P10-P30 M10-M25	K10-K25	K20-K35	N05-N20	N10-N30

Chip breaker

ODHT-GL



Finishing

ODHT-GM



General machining

ODHT-GH



Roughing

ODHT-LH



Aluminium machining

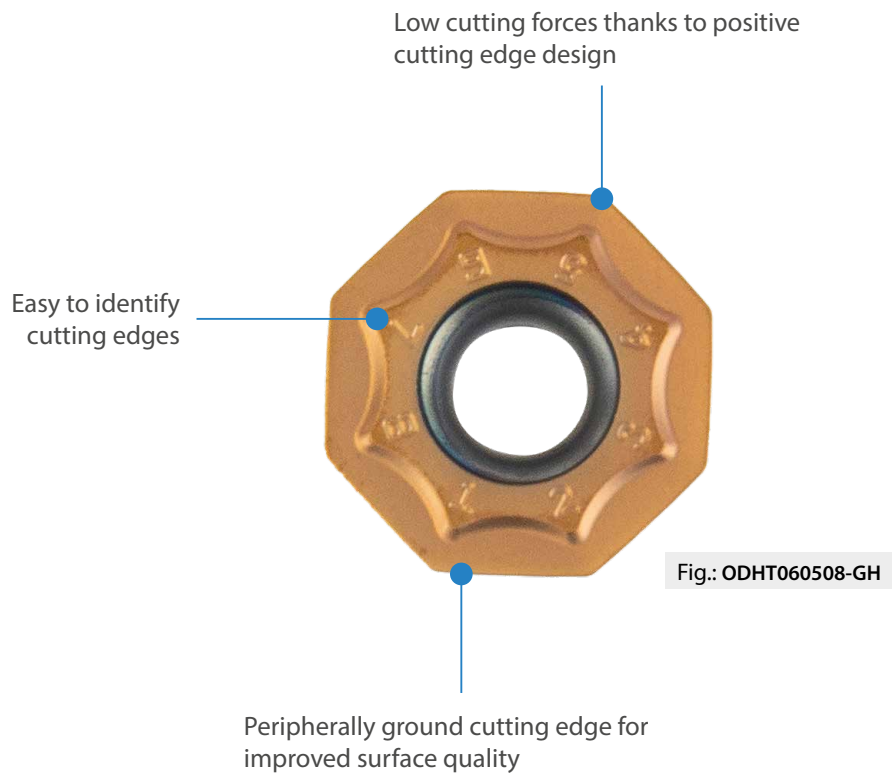

Face milling

FMA04 Kr: 45°

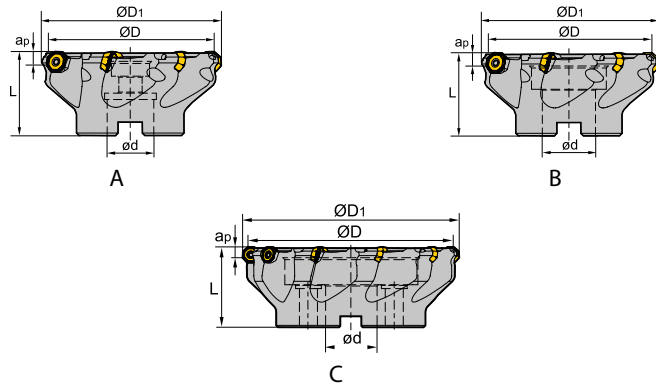
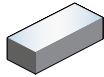

Article	*	Stock	Dimensions [mm]					Teeth	Coupling	kg	Insert
			ØD	ØD ₁	ød	L	a _{p max}				
FMA04-050-A22-OD06-04C	*	●	50	60	22	40	4	4	A	0,284	ODHT0605
FMA04-063-A22-OD06-05C	*	●	63	73	27	40	4	5	A	0,409	
FMA04-080-A27-OD06-06C	*	●	80	90	27	50	4	6	A	1,017	
FMA04-100-A32-OD06-07C	*	●	100	110	32	50	4	7	A	1,536	
FMA04-125-B40-OD06-08		●	125	135	40	63	4	8	B	2,931	
FMA04-160-C40-OD06-10		●	160	170	40	63	4	10	C	3,838	



● Ex stock ○ On demand

* With internal cooling











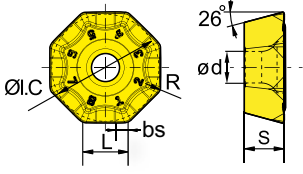









Spare parts		
	Insert	OD*T0605**
	ØD	50-160
	Screw (Insert)	I60M5*13 (5,0 Nm)
	Wrench (Insert)	WT20IP
	Wrench (Insert)	WT20IS



Milling insert

-  Ideal machining conditions
-  Normal machining conditions
-  Unfavourable machining conditions

ODHT	L	I.C	S	d
06 05	6,50	15,875	5,56	5,40

OD*T milling insert			HC ¹ (CVD)			HC ¹ (PVD)		HT	HC ²	HW	
			P								
			M								
			K								
			N								
			S								
			H								
ISO	r	bs	YBM253	YBD252 YBD152	YB9320 YBG205			YD101 YD201			
 ODHT060508-GL	0,8		•	•	• •						
 ODMT060512-GM	1,2	1,6	•	•	• •						
 ODHT060508-GM	0,8		•	•	• •						
 ODHT060508-GH	0,8		•	•	• •						
 ODHT060508-LH	0,8							• •			

● Ex stock ○ On demand

HC¹ Coated carbide
 HT Uncoated cermet
 HC² Coated cermet
 HW Uncoated carbide

A

Turning

B

Milling

C

Drilling

D

Technical Information

E

Index

FMWX face milling system

Maximum precision and ultra-high surface qualities

YOUR BENEFITS

- High surface qualities made possible thanks to precision-ground wiper indexable insert
- Ultra-high precision insert seats ensure high repeatability
- Wide range of applications possible thanks to CVD/PVD coated indexable inserts
- No adjustments necessary because seats are compatible with inserts
- Reserve insert seats increase longevity of milling body

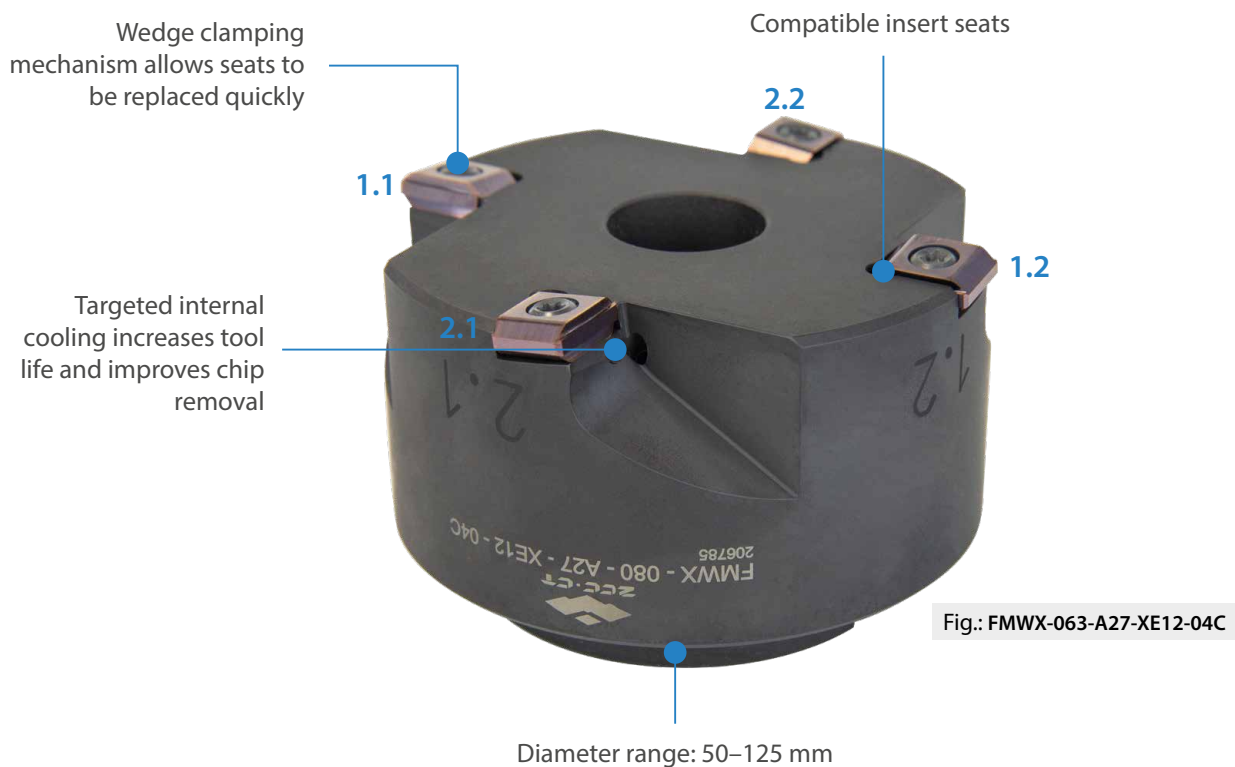

 The milling body is only equipped with two opposing inserts.

Insert grades

YBG105

PVD
S05–S20

YBD152

CVD
K10–K25

Wiper indexable insert

XEEC

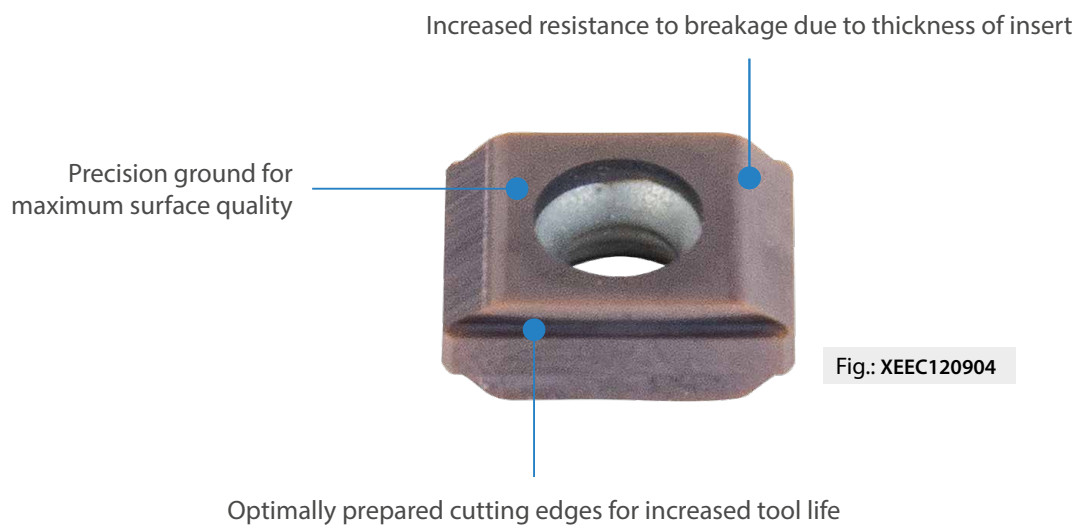

Cutting data

ISO group	Material	v_c (m/min)	F_m	a_p
P	Low-alloy steel	300–400	3,50–5,00	0,02–0,05
M	Stainless steels	280–300	3,50–5,00	0,02–0,05
K	Cast steel	300–400	3,50–5,00	0,02–0,05

Face milling

FMWX

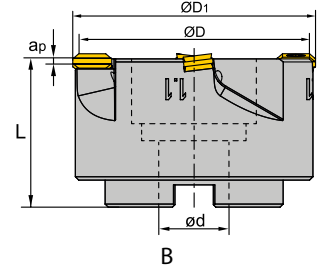
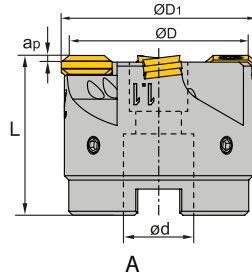
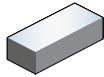

Article	*	Stock	Dimensions [mm]					Teeth	Coupling	kg	Insert
			$\varnothing D$	$\varnothing D_1$	$\varnothing d$	L	$a_{p\max}$				
FMWX-050-A22-XE12-04C	*	●	46	50	22	40	0,1	2 (4)	A	0,3	XEEC120904
FMWX-063-A27-XE12-04C	*	●	59	63	27	40	0,1	2 (4)	A	0,5	
FMWX-080-A27-XE12-04C	*	●	76	80	27	50	0,1	2 (4)	A	1	
FMWX-100-B32-XE12-06C	*	●	96	100	32	50	0,1	2 (6)	B	1,9	
FMWX-125-B40-XE12-06C	*	●	121	125	40	63	0,1	2 (6)	B	3,5	

● Ex stock ○ On demand

* With internal cooling

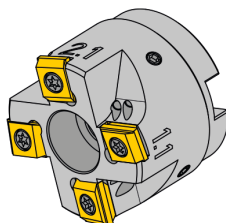

Spare parts		
	Insert $\varnothing D$	XEEC1209 50-125
	Screw (Insert)	I60M4*10 (3,4 Nm)
	Wrench (Insert)	WT15IS
	Grub screw	DIN913 M4*4
	Wrench (Grub screw)	WH20L



- Ideal machining conditions
- ⊗ Normal machining conditions
- ⊗ Unfavourable machining conditions

XEEC	L	I.C	S	d
12 09	12,7	9,525	4,76	4,40

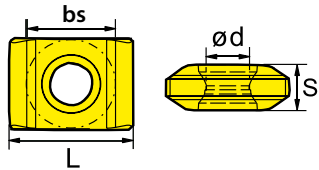
Milling insert

XEEC milling insert			HC ¹ (CVD)	HC ¹ (PVD)	HT	HC ²	HW
	P		⊗	⊗			
	M			⊗			
	K		⊗				
	N			⊗			
	S				⊗		
	H						
ISO		bs	YBD152	YBG105			
	XEEC120904	7,3	●	●			

● Ex stock ○ On demand

HC¹ Coated carbide
 HT Uncoated cermet
 HC² Coated cermet
 HW Uncoated carbide

A

Turning

B

Milling

C

Drilling

D

Technical Information

E

Index

Notes

A

Turning

B

Milling

C

Drilling

D

Technical
Information

E

Index

Notes section with horizontal dotted lines for writing.

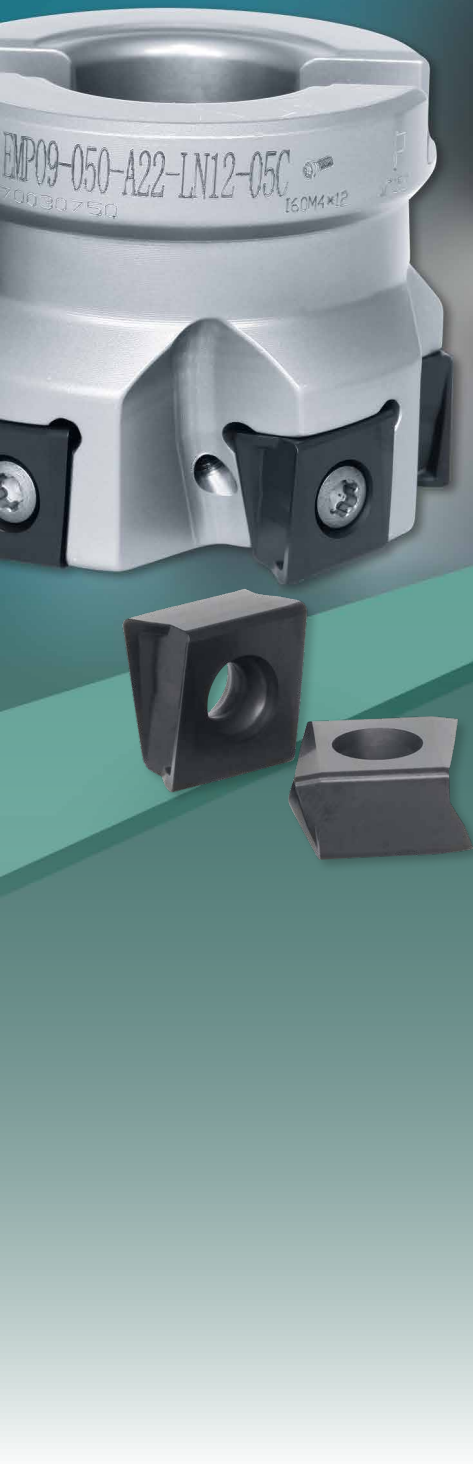

EMP09 *Kr: 90°*

Square shoulder mill with tangential inserts

- Sharp cutting edge geometry combined with robust tangential inserts
- First choice for large cutting depths with high feed rates
- Very good competitiveness

Insert grades

YBC302	YBM253	YB9320	YBD152	YBD252
CVD P15 – P35	CVD P20 – P40 M10 – M30	PVD P10 – P30 M20 – M30	CVD K05 – K25	CVD K15 – K35
YBS303				
PVD S25 – P35				

Chip breaker

-GM



-GL



New

- Sharp cutting edge geometry for lower cutting forces
- Highly suitable for difficult-to-machine materials and stainless steels



A

Turning

B

Milling

C



Drilling

D

Technical Information











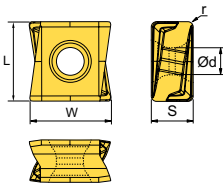



E

Index

-  Ideal machining conditions
-  Normal machining conditions
-  Unfavourable machining conditions

LNKT	L	S
08 04	8,75	4,45
12 06	12,7	6,75
16 07	16,05	7,35

Milling insert

LN** milling insert				HC ¹ (CVD)		HC ¹ (PVD)		HT	HC ²	HW		
		P										
		M										
		K										
		N										
		S										
		H										
ISO		W	r	YBM253	YBD152	YBD252	YBC302	YB9320	YBS303			
	LNKT080404PNR-GL NEW!	8,75	0,4			●		●	●			
	LNKT080408PNR-GL NEW!	8,75	0,8									
	LNKT120608PNR-GL NEW!	12,7	0,8			●		●	●			
	LNKT160708PNR-GL NEW!	16,05	0,8			●		●	●			
	LNKT080404PNR-GM	8,75	0,4	●	●			●	●			
	LNKT080408PNR-GM	8,75	0,8		●			●				
	LNKT080412PNR-GM	8,75	1,2		●							
	LNKT120608PNR-GM	12,7	0,8	●	●	●		●				
	LNKT120612PNR-GM	12,7	1,2	●	●	●		●				
	LNKT120616PNR-GM	12,7	1,6		●			●				
	LNKT120624PNR-GM	12,7	2,4					●				
	LNKT120632PNR-GM	12,7	3,2					●				
	LNKT160708PNR-GM	16,05	0,8	●	●	●		●				
	LNKT160716PNR-GM	16,05	1,6					●				
LNKT160732PNR-GM	16,05	3,2					●					

● Ex stock ○ On demand

HC¹ Coated carbide
 HT Uncoated cermet
 HC² Coated cermet
 HW Uncoated carbide

Indexable milling – group 1 (FMA07/11/12, FMD02, EMP09/13)

	Material group	Composition / structure / heat treatment		Machining group	Starting values for cutting speed v_c [m/min]								
					HC (CVD)								
					YBC302		YBC401		YBD152		YBD252		
					a_e / D		a_e / D		a_e / D		a_e / D		
					1/1 3/4	1/5	1/1 3/4	1/5	1/1 3/4	1/5	1/1 3/4	1/5	
P	Unalloyed steel	approx. 0,15 % C	annealed	125	1	260	300	225	260				
		approx. 0,45 % C	annealed	190	2	225	255	195	225				
		approx. 0,45 % C	tempered	250	3	210	240	180	210				
		approx. 0,75 % C	annealed	270	4	185	210	160	185				
		approx. 0,75 % C	tempered	300	5	170	195	150	170				
P	Low-alloyed steel		annealed	180	6	225	255	195	225				
			tempered	275	7	185	210	160	185				
			tempered	300	8	170	195	150	170				
			tempered	350	9	145	165	125	145				
P	High-alloyed steel and high-alloyed tool steel		annealed	200	10	130	150	115	130				
			hardened and tempered	325	11	95	105	80	95				
M	Stainless steel	ferritic/martensitic	annealed	200	12								
			tempered	240	13								
		austenitic	quench hardened	180	14								
				230	15								
K	Grey cast iron	perlitic/ferritic		180	16				370	430	320	370	
		perlitic (martensitic)		260	17				220	255	190	220	
	Cast iron with spheroidal graphite	ferritic		160	18				255	295	220	255	
		perlitic		250	19				170	200	145	170	
K	Malleable cast iron	ferritic		130	20				305	355	265	305	
		perlitic		230	21				205	240	175	205	
N	Aluminium wrought alloys	cannot be hardened		60	22								
		hardenable	hardened	100	23								
	Cast aluminium alloys	$\leq 12\% \text{ Si}$, cannot be hardened		75	24								
		$\leq 12\% \text{ Si}$, hardenable	hardened	90	25								
		$> 12\% \text{ Si}$, cannot be hardened		130	26								
	Copper and copper alloys (bronze/brass)	machining steel, PB > 1%		110	27								
CuZn, CuSnZn		90	28										
CuSn, Pb-free copper, electrolytic copper		100	29										
S	Heat-resistant alloys	Fe-based alloys	annealed	200	30								
			hardened	280	31								
		Ni or Co base	annealed	250	32								
			hardened	350	33								
		cast	320	34									
Titanium alloys	pure titanium		R_m 400	35									
	α and β alloys		hardened	R_m 1050	36								
H	Hardened steel	hardened and tempered		55 HRC	37								
		hardened and tempered		60 HRC	38								
	Hard cast iron	cast		400	39								
X	Non-metallic materials	hardened and tempered		55 HRC	40								
		Thermoplasts			41								
		Thermosetting plastics			42								
		Plastic, glass-fibre reinforced GFRP			43								
	Plastic, carbon fibre reinforced CFRP			44									
	Graphite			45									
	Wood			46									

Note: The given cutting values are guide values, which were determined under ideal conditions.
 The values have to be adapted in individual cases.
 Feed rate recommendations on page B248.
 For examples of material for cutting tool groups view page D22.

A

Turning

B

Milling

C

Drilling

D

Technical Information

E

Index

Starting values for cutting speed v_c [m/min]															
HC (CVD)		HC (PVD)								HW					
YBM253		YBG102		YB9320		YBG205		YBG252		YBG302		YD101		YD201	
a_e / D		a_e / D		a_e / D		a_e / D		a_e / D		a_e / D		a_e / D		a_e / D	
1/1 3/4	1/5	1/1 3/4	1/5	1/1 3/4	1/5	1/1 3/4	1/5	1/1 3/4	1/5	1/1 3/4	1/5	1/1 3/4	1/5	1/1 3/4	1/5
260	300	270	315	245	285	235	275	230	265	225	260				
225	255	230	270	210	245	200	235	200	230	195	225				
210	240	220	255	200	230	190	220	185	215	180	210				
185	210	190	225	175	200	165	195	165	190	160	185				
170	195	180	205	160	190	155	180	150	175	150	170				
225	255	230	270	210	245	200	235	200	230	195	225				
185	210	190	225	175	200	165	195	165	190	160	185				
170	195	180	205	160	190	155	180	150	175	150	170				
145	165	150	175	135	160	130	155	130	150	125	145				
130	150	135	160	125	145	120	140	115	135	115	130				
95	105	95	115	90	100	85	100	85	95	80	95				
130	150	135	160	125	145	120	140	115	135	115	130				
110	130	115	135	105	120	100	120	100	115	95	110				
140	160	145	170	130	155	125	150	125	145	120	140				
110	130	115	135	105	120	100	120	100	115	95	110				
		300	345	270	315	260	300	255	295	250	290				
		180	205	160	190	155	180	150	175	150	170				
		205	240	185	215	180	210	175	200	170	195				
		135	160	125	145	120	140	115	135	115	130				
		245	285	225	260	215	250	210	240	205	235				
		165	190	150	175	145	165	140	160	135	160				
												1505	1735	1450	1670
												1225	1420	1180	1370
												540	620	515	600
												435	505	420	485
												220	255	215	250
												170	195	160	190
												210	245	205	235
												385	445	370	430

HC Coated carbide
 HT Uncoated carbide, main component (TiC) o. (TiN), cermet
 HC₁ Coated cermet
 HW Uncoated carbide, main component (WC)

A

Turning

B

Milling

C

Drilling

D

Technical Information

E

Index

Indexable milling – group 2 (FMA01/02/03/04, FME01/02, EMP01/02/03/04)

Material group	Composition / structure / heat treatment		Machining group	Starting values for cutting speed v_c [m/min]									
				HC (CVD)									
				YBC302		YBC401		YBD152		YBD252			
				a_e / D		a_e / D		a_e / D		a_e / D			
				1/1 3/4	1/5	1/1 3/4	1/5	1/1 3/4	1/5	1/1 3/4	1/5		
P Unalloyed steel	approx. 0,15 % C	annealed	125	1	245	285	210	245					
	approx. 0,45 % C	annealed	190	2	210	245	180	210					
	approx. 0,45 % C	tempered	250	3	200	230	170	200					
	approx. 0,75 % C	annealed	270	4	175	200	150	175					
	approx. 0,75 % C	tempered	300	5	160	190	140	160					
P Low-alloyed steel		annealed	180	6	210	245	180	210					
		tempered	275	7	175	200	150	175					
		tempered	300	8	160	190	140	160					
		tempered	350	9	135	160	120	135					
High-alloyed steel and high-alloyed tool steel		annealed	200	10	125	145	105	125					
		hardened and tempered	325	11	90	100	75	90					
M Stainless steel	ferritic/martensitic	annealed	200	12									
	martensitic	tempered	240	13									
	austenitic	quench hardened	180	14									
	austenitic-ferritic		230	15									
K Grey cast iron	perlitic/ferritic		180	16				315	365	270	315		
	perlitic (martensitic)		260	17				185	215	160	190		
K Cast iron with spheroidal graphite	ferritic		160	18				215	250	185	215		
	perlitic		250	19				145	170	125	145		
K Malleable cast iron	ferritic		130	20				260	300	225	260		
	perlitic		230	21				175	205	150	175		
N Aluminium wrought alloys	cannot be hardened		60	22									
	hardenable	hardened	100	23									
	$\leq 12\% \text{ Si}$, cannot be hardened		75	24									
	$\leq 12\% \text{ Si}$, hardenable		hardened	90	25								
	$> 12\% \text{ Si}$, cannot be hardened			130	26								
N Cast aluminium alloys	machining steel, PB > 1%		110	27									
	CuZn, CuSnZn		90	28									
	CuSn, Pb-free copper, electrolytic copper		100	29									
S Copper and copper alloys (bronze/brass)													
	Fe-based alloys	annealed	200	30									
		hardened	280	31									
	Ni or Co base	annealed	250	32									
		hardened	350	33									
cast		320	34										
S Titanium alloys	pure titanium		R_m 400	35									
	α and β alloys		hardened	R_m 1050	36								
H Hardened steel													
			hardened and tempered	55 HRC	37								
		hardened and tempered	60 HRC	38									
H Hard cast iron			cast	400	39								
H Hardened cast iron			hardened and tempered	55 HRC	40								
X Non-metallic materials	Thermoplasts			41									
	Thermosetting plastics			42									
	Plastic, glass-fibre reinforced GFRP			43									
	Plastic, carbon fibre reinforced CFRP			44									
	Graphite			45									
	Wood			46									

Note: The given cutting values are guide values, which were determined under ideal conditions.
 The values have to be adapted in individual cases.
 Feed rate recommendations on page B248.
 For examples of material for cutting tool groups view page D22.

Starting values for cutting speed v_c [m/min]																					
HC (CVD)				HC (PVD)												HW				HT	
YBM253		YBG101		YBG102		YBG152		YB9320		YBG205		YBG252		YBG302		YD101		YD201		YNG151	
a_e / D		a_e / D		a_e / D		a_e / D		a_e / D		a_e / D		a_e / D		a_e / D		a_e / D		a_e / D		a_e / D	
1/1 3/4	1/5	1/1 3/4	1/5	1/1 3/4	1/5	1/1 3/4	1/5	1/1 3/4	1/5	1/1 3/4	1/5	1/1 3/4	1/5	1/1 3/4	1/5	1/1 3/4	1/5	1/1 3/4	1/5	1/1 3/4	1/5
245	285			255	295	240	280	230	265	220	255	215	250	210	245					270	315
210	245			220	255	205	240	200	230	190	220	185	215	180	210					235	270
200	230			205	240	195	225	185	215	180	205	175	200	170	200					220	255
175	200			180	210	170	200	165	190	155	180	155	175	150	175					195	220
160	190			170	195	160	185	150	175	145	170	140	165	140	160					180	210
210	245			220	255	205	240	200	230	190	220	185	215	180	210					235	270
175	200			180	210	170	200	165	190	155	180	155	175	150	175					195	220
160	190			170	195	160	185	150	175	145	170	140	165	140	160					180	210
135	160			145	165	135	155	130	150	125	145	120	140	120	135					150	180
125	145			130	150	120	140	115	135	110	130	110	125	105	125					140	160
90	100			90	105	85	100	85	95	80	90	80	90	75	90					100	110
125	145			130	150	120	140	115	135	110	130	110	125	105	125					135	160
105	120			110	125	105	120	100	115	95	110	95	105	90	105					115	135
130	155			140	160	130	150	125	145	120	140	115	135	115	130					145	170
105	120			110	125	105	120	100	115	95	110	95	105	90	105					115	135
				285	330	265	305	255	295	245	285	240	280	235	275						
				170	195	160	185	150	175	145	170	140	165	140	160						
				195	225	180	210	175	200	165	195	165	190	160	185						
				130	150	120	140	115	135	110	130	110	125	105	125						
				230	270	220	255	210	240	200	230	195	225	190	225						
				155	180	145	170	140	160	135	155	130	150	130	150						
		1505	1735													1205	1390	1040	1200		
		1225	1420													980	1140	850	980		
		540	620													435	500	375	435		
		435	505													350	405	300	350		
		220	255													180	205	155	180		
		170	195													140	160	120	140		
		210	245													170	200	150	170		
		385	445													310	360	265	310		
				75	85	70	80	65	75	65	75	65	75	60	70						
				50	55	50	55	45	50	45	50	45	50	40	45						
				60	70	55	65	55	65	50	55	50	55	50	55						
				35	40	35	40	30	35	30	35	30	35	30	35						
				45	50	45	50	40	45	40	45	40	45	40	45						
				75	85	70	80	65	75	65	75	65	75	60	70						
				75	85	70	80	65	75	65	75	65	75	60	70						

HC Coated carbide
 HT Uncoated carbide, main component (TiC) o. (TiN), cermet
 HC₁ Coated cermet
 HW Uncoated carbide, main component (WC)

A

Turning

B

Milling

C

Drilling

D

Technical Information

E

Index

Recommended feed rate

Indexable milling – group1 (FMA07/11/12, FMD02, EMP09/13)

Material group	Feed rate per cutting edge [mm]																	
	EMP09			EMP09			EMP13			EMP13			FMA07			FMA07		
	LNKT08/12			LNKT16			ANGX11			ANGX15			ONHU06			ONHU08		
	Application																	
	F	M	R	F	M	R	F	M	R	F	M	R	F	M	R	F	M	R
P Unalloyed steel		0,25	0,50		0,28	0,55		0,23			0,25		0,19	0,23		0,19	0,23	
	Low-alloyed steel	0,23	0,47	0,26	0,51	0,22	0,23	0,17	0,22	0,17	0,22							
	High-alloyed steel and high-alloyed tool steel	0,22	0,44	0,24	0,48	0,20	0,22	0,16	0,20	0,16	0,20							
M Stainless steel	0,18	0,35	0,19	0,39	0,16	0,18												
K Grey cast iron	0,28	0,55	0,30	0,61	0,26	0,28	0,20	0,26	0,20	0,26								
	Cast iron with spheroidal graphite	0,25	0,50	0,28	0,55	0,23	0,25	0,19	0,23	0,19	0,23							
	Malleable cast iron	0,25	0,50	0,28	0,55	0,23	0,25	0,19	0,23	0,19	0,23							
N Aluminum wrought alloys							0,20	0,21										
	Aluminum cast alloys						0,20	0,21										
	Copper and copper alloys (bronze/brass)						0,18	0,19										
S Heat-resistant alloys																		
	Titanium alloys																	
H Hardened steel																		
	Hard cast iron																	
	Hardened cast iron																	
X Non-metallic materials																		

Note: The given cutting values are guide values, which were determined under ideal conditions.
The values have to be adapted in individual cases.

Indexable milling – group 2 (FMA01/02/03/04, FME01/02, EMP01/02/03/04)

Material group	Feed rate per cutting edge [mm]																	
	FMA01 FMA02			FMA03			FMA03			FMA04			FMA04					
	SEET12			SEKN12			SEKN15			OFKT05			OFKR07			ODHT06		
	Application																	
	F	M	R	F	M	R	F	M	R	F	M	R	F	M	R	F	M	R
P Unalloyed steel	0,15	0,20	0,25	0,18			0,20	0,20	0,25	0,20	0,25	0,20	0,25	0,20	0,25			
	Low-alloyed steel	0,14	0,19	0,23	0,17			0,19	0,19	0,23	0,19	0,23	0,19	0,23				
	High-alloyed steel and high-alloyed tool steel	0,13	0,18	0,22	0,16			0,18	0,18	0,22	0,18	0,22	0,18	0,22				
M Stainless steel	0,11	0,14	0,18	0,13			0,14	0,14	0,18	0,14	0,18	0,14	0,18					
K Grey cast iron	0,17	0,22	0,28	0,20			0,22	0,22	0,28	0,22	0,28	0,22	0,28					
	Cast iron with spheroidal graphite	0,15	0,20	0,25	0,18			0,20	0,20	0,25	0,20	0,25	0,20	0,25				
	Malleable cast iron	0,15	0,20	0,25	0,18			0,20	0,20	0,25	0,20	0,25	0,20	0,25				
N Aluminium wrought alloys	0,13	0,17	0,21					0,17	0,21	0,17	0,21	0,17	0,21					
	Aluminum cast alloys	0,13	0,17	0,21					0,17	0,21	0,17	0,21	0,17	0,21				
	Copper and copper alloys (bronze/brass)	0,11	0,15	0,19					0,15	0,19	0,15	0,19	0,15	0,19				
S Heat-resistant alloys	0,11	0,14	0,18					0,14	0,18	0,14	0,18	0,14	0,18					
	Titanium alloys	0,11	0,14	0,18					0,14	0,18	0,14	0,18	0,14	0,18				
H Hardened steel																		
	Hard cast iron																	
	Hardened cast iron																	
X Non-metallic materials																		

Note: The given cutting values are guide values, which were determined under ideal conditions.
The values have to be adapted in individual cases.

A

GM – 2 E L P – D12 R0.5 – M08

1

2

3

4

5

6

7

8

Turning

Application	
Code	Description
GR	General roughing
GM	Semi-finishing
GF	Finishing
PM	High-performance machining
HM	Hard machining
HH	High-speed hard machining
NM	General machining of non-ferrous metals
AL	General machining of Al and Al alloys
ALP	High-performance machining of Al and Al alloys
ALG	General machining of Al and Al alloys
UM	HSC/HPC machining
VSM	General machining of heat-resistant alloys

Number of teeth

1

2

B

Milling

Cutting edge type	
Code	Description
E	Square shoulder mill with protective chamfer
F	Square shoulder mill with sharp cutting edges
B	Ball nose cutter
R	Torus mill
W	Ripper
H	High-feed mill

Cutting edge length	
Code	Description
L	Long
X	Extra long
F	Short

3

4

C

Drilling

Type	
Code	Description
S	Mini diameter
P	Ground neck
C	Conical neck

Diameter [mm]	
Code	Description
D3.0	3,0
D8.0	8,0
D20.0	20,0
...	

5

6

D

Technical Information

Radius [mm]	
Code	Description
R0.5	0,5
R1.0	1,5
R3.0	3,0
...	

Features	
Code	Description
G	Spiral angle 30°
M	Neck length [mm]
S	Thin shank
AIR	For aerospace industry

7

8

E

Index

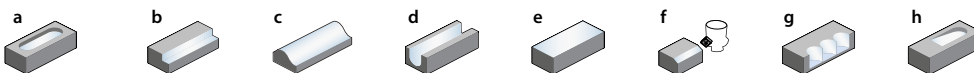

a Groove milling b Square shoulder milling c Profile milling d Slot milling e Face milling f Chamfer milling g Plunge milling
h Circular milling/Ramping

ALP/ALG series

For high-performance aluminium machining



ALP-1EP: single-edged tools for full-slot machining and profiling

- Optimised Geometries for top results in aluminium machining operations
 - ALP series optimised for roughing operations with maximal chip removal rates
 - ALG series specially designed for finishing operations with high surface qualities
- Available with optional DLC coating (KMD401) for improved performance and reduced wear
- End/torus mills
- Diameter range: 1.0–20.0 mm



A

End mill General machining of Al and Al alloys



ALP-1EP

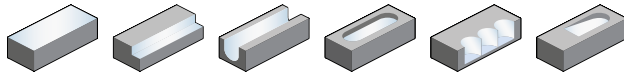

- Factory standard
- Centre cutting
- Helix angle 23°

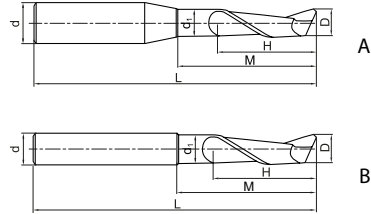

Turning

B

Milling

Article	*	Dimensions [mm]						Teeth	Geometry	Grade	
		D	d (h5)	d ₁	H	M	L			KMD401	YK40F
ALP-1EP-D2.0-M08S		2	4	1,8	6	8	45	1	A	○	○
ALP-1EP-D2.0-M12S		2	4	1,8	6	12	45	1	A	○	○
ALP-1EP-D3.0-M12S		3	4	2,8	8	12	45	1	A	○	○
ALP-1EP-D3.0-M18S		3	4	2,8	8	18	45	1	A	○	○
ALP-1EP-D4.0-M16S		4	4	3,8	10	16	45	1	B	○	○
ALP-1EP-D4.0-M24S		4	4	3,8	10	24	45	1	B	○	○
ALP-1EP-D2.0-M08		2	6	1,8	6	8	45	1	A	●	●
ALP-1EP-D2.0-M12		2	6	1,8	6	12	45	1	A	●	●
ALP-1EP-D3.0-M12		3	6	2,8	8	12	45	1	A	●	●
ALP-1EP-D3.0-M18		3	6	2,8	8	18	45	1	A	●	●
ALP-1EP-D4.0-M16		4	6	3,8	10	16	45	1	A	●	●
ALP-1EP-D4.0-M24		4	6	3,8	10	24	55	1	A	●	●
ALP-1EP-D5.0-M20		5	6	4,8	13	20	55	1	A	●	●
ALP-1EP-D5.0-M30		5	6	4,8	13	30	65	1	A	●	●
ALP-1EP-D6.0-M24		6	6	5,8	16	24	55	1	B	●	●
ALP-1EP-D6.0-M36		6	6	5,8	16	36	75	1	B	●	●
ALP-1EP-D8.0-M32		8	8	7,7	22	32	75	1	B	●	●
ALP-1EP-D8.0-M48		8	8	7,7	22	48	90	1	B	●	●
ALP-1EP-D10.0-M40		10	10	9,6	27	40	80	1	B	●	●
ALP-1EP-D10.0-M60		10	10	9,6	27	60	100	1	B	●	●

● Ex stock ○ On demand

* With internal cooling

C

Drilling

D

Technical Information

Application field

P	M	K	N	S	H
			✓		

✓ Very suitable

✓ Suitable

E

Index

End mill

General machining of Al and Al alloys

ALG-2E

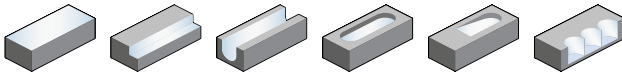

- Factory standard
- Centre cutting
- Helix angle 30°

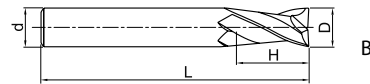
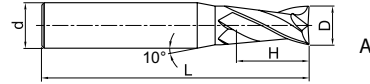

Article	*	Dimensions [mm]				Teeth	Geometry	Grade
		D	d (h6)	H	L			YK40F
ALG-2E-D1.0		1	4	3	50	2	A	●
ALG-2E-D1.5		1,5	4	4	50	2	A	○
ALG-2E-D2.0		2	4	6	50	2	A	●
ALG-2E-D2.5		2,5	4	8	50	2	A	○
ALG-2E-D3.0S		3	4	8	50	2	A	●
ALG-2E-D3.5S		3,5	4	10	50	2	A	○
ALG-2E-D4.0S		4	4	11	50	2	B	○
ALG-2E-D3.0		3	6	8	50	2	A	●
ALG-2E-D3.5		3,5	6	10	50	2	A	○
ALG-2E-D4.0		4	6	11	50	2	A	●
ALG-2E-D4.5		4,5	6	11	50	2	A	○
ALG-2E-D5.0		5	6	13	50	2	A	●
ALG-2E-D5.5		5,5	6	16	50	2	A	○
ALG-2E-D6.0		6	6	16	50	2	B	●
ALG-2E-D7.0		7	8	20	60	2	A	○
ALG-2E-D8.0		8	8	20	60	2	B	●
ALG-2E-D9.0		9	10	22	75	2	A	○
ALG-2E-D10.0		10	10	25	75	2	B	●
ALG-2E-D11.0		11	12	26	75	2	A	○
ALG-2E-D12.0		12	12	30	75	2	B	●
ALG-2E-D14.0		14	14	32	75	2	B	●
ALG-2E-D16.0		16	16	45	100	2	B	●
ALG-2E-D18.0		18	18	45	100	2	B	○
ALG-2E-D20.0		20	20	45	100	2	B	●

● Ex stock ○ On demand

* With internal cooling

Application field

P	M	K	N	S	H
			✓		

✓ Very suitable

✓ Suitable

A

Turning

B

Milling

C

Drilling

D

Technical
Information

E

Index

A

End mill General machining of Al and Al alloys

ALG-3E

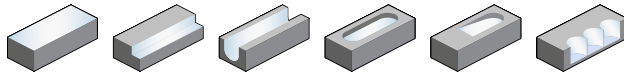

- Factory standard
- Centre cutting
- Helix angle 45°

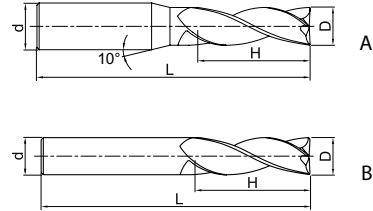

Turning

B

Milling

Article	*	Dimensions [mm]				Teeth	Geometry	Grade	
		D	d (h6)	H	L			KMD401	YK40F
ALG-3E-D1.0		1	4	3	50	3	A	○	●
ALG-3E-D1.5		1,5	4	4	50	3	A	○	●
ALG-3E-D2.0		2	4	6	50	3	A	○	●
ALG-3E-D2.5		2,5	4	8	50	3	A	○	○
ALG-3E-D3.0S		3	4	8	50	3	A	○	●
ALG-3E-D3.5S		3,5	4	10	50	3	A	○	○
ALG-3E-D4.0S		4	4	11	50	3	B	○	●
ALG-3E-D3.0		3	6	8	50	3	A	●	●
ALG-3E-D3.5		3,5	6	10	50	3	A	●	○
ALG-3E-D4.0		4	6	11	50	3	A	●	●
ALG-3E-D4.5		4,5	6	11	50	3	A	●	○
ALG-3E-D5.0		5	6	13	50	3	A	●	●
ALG-3E-D5.5		5,5	6	16	50	3	A	●	○
ALG-3E-D6.0		6	6	16	50	3	B	●	●
ALG-3E-D7.0		7	8	20	60	3	A	●	○
ALG-3E-D8.0		8	8	20	60	3	B	●	●
ALG-3E-D9.0		9	10	22	75	3	A	●	○
ALG-3E-D10.0		10	10	25	75	3	B	●	●
ALG-3E-D11.0		11	12	26	75	3	A	●	○
ALG-3E-D12.0		12	12	30	75	3	B	●	●
ALG-3E-D14.0		14	14	32	75	3	B	●	●
ALG-3E-D16.0		16	16	45	100	3	B	●	●
ALG-3E-D18.0		18	18	45	100	3	B	●	○
ALG-3E-D20.0		20	20	45	100	3	B	○	●

● Ex stock ○ On demand

* With internal cooling

C

Drilling

D

Technical Information

E

Index

Application field

P	M	K	N	S	H
			✓		

✓ Very suitable

✓ Suitable

End mill

General machining of Al and Al alloys

ALG-3E-W

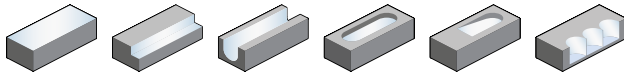

- Factory standard
- Centre cutting
- Helix angle 45°

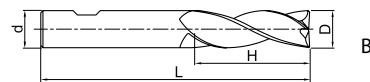
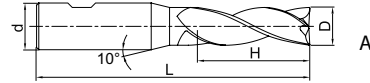

Article	*	Dimensions [mm]				Teeth	Geometry	Grade
		D	d (h6)	H	L			KMD401
ALG-3E-D3.0-W		3	6	8	50	3	A	●
ALG-3E-D3.5-W		3,5	6	10	50	3	A	●
ALG-3E-D4.0-W		4	6	11	50	3	A	●
ALG-3E-D4.5-W		4,5	6	11	50	3	A	●
ALG-3E-D5.0-W		5	6	13	50	3	A	●
ALG-3E-D5.5-W		5,5	6	16	50	3	A	●
ALG-3E-D6.0-W		6	6	16	50	3	B	●
ALG-3E-D7.0-W		7	8	20	60	3	A	●
ALG-3E-D8.0-W		8	8	20	60	3	B	●
ALG-3E-D9.0-W		9	10	22	75	3	A	●
ALG-3E-D10.0-W		10	10	25	75	3	B	●
ALG-3E-D11.0-W		11	12	26	75	3	A	●
ALG-3E-D12.0-W		12	12	30	75	3	B	●
ALG-3E-D14.0-W		14	14	32	75	3	B	●
ALG-3E-D16.0-W		16	16	45	100	3	B	●
ALG-3E-D18.0-W		18	18	45	100	3	B	●
ALG-3E-D20.0-W		20	20	45	100	3	B	●

● Ex stock ○ On demand

* With internal cooling

Application field

P	M	K	N	S	H
			✓		

✓ Very suitable

✓ Suitable

A

Turning

B

Milling

C

Drilling

D

Technical
Information

E

Index

A

End mill General machining of Al and Al alloys

ALG-2R

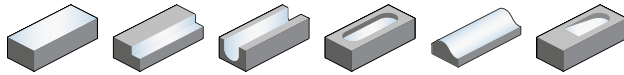

- Factory standard
- Centre cutting
- Helix angle 30°

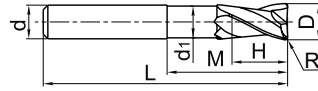

Turning

B

Article	*	Dimensions [mm]								Teeth	Grade	
		R	D	d (h6)	d ₁	H	M	L	KMD401		YK40F	
ALG-2R-D6.0R0.3		0,3	6	6	5,7	8	16	75	2	●	●	
ALG-2R-D6.0R0.5		0,5	6	6	5,7	8	16	75	2	●	●	
ALG-2R-D6.0R1.0		1	6	6	5,7	8	16	75	2	●	●	
ALG-2R-D8.0R0.3		0,3	8	8	7,4	10	20	75	2	●	●	
ALG-2R-D8.0R0.5		0,5	8	8	7,4	10	20	75	2	●	●	
ALG-2R-D8.0R1.0		1	8	8	7,4	10	20	75	2	●	●	
ALG-2R-D10.0R0.5		0,5	10	10	9,4	12	35	100	2	●	●	
ALG-2R-D10.0R1.0		1	10	10	9,4	12	35	100	2	●	●	
ALG-2R-D10.0R1.6		1,6	10	10	9,4	12	35	100	2	●	●	
ALG-2R-D10.0R2.5		2,5	10	10	9,4	12	35	100	2	●	●	
ALG-2R-D12.0R0.5		0,5	12	12	11,4	15	35	100	2	●	●	
ALG-2R-D12.0R1.0		1	12	12	11,4	15	35	100	2	●	●	
ALG-2R-D12.0R1.6		1,6	12	12	11,4	15	35	100	2	●	●	
ALG-2R-D12.0R2.5		2,5	12	12	11,4	15	35	100	2	●	●	
ALG-2R-D12.0R3.2		3,2	12	12	11,4	15	35	100	2	●	●	
ALG-2R-D12.0R4.0		4	12	12	11,4	15	35	100	2	●	●	
ALG-2R-D16.0R1.0		1	16	16	15,4	15	45	125	2	●	●	
ALG-2R-D16.0R1.6		1,6	16	16	15,4	15	45	125	2	●	●	
ALG-2R-D16.0R2.5		2,5	16	16	15,4	15	45	125	2	●	●	
ALG-2R-D16.0R3.2		3,2	16	16	15,4	15	45	125	2	●	●	
ALG-2R-D16.0R4.0		4	16	16	15,4	15	45	125	2	●	●	
ALG-2R-D16.0R6.3		6,3	16	16	15,4	15	45	125	2	○	○	
ALG-2R-D20.0R1.0		1	20	20	18	20	50	125	2	●	●	
ALG-2R-D20.0R1.6		1,6	20	20	18	20	50	125	2	●	●	
ALG-2R-D20.0R2.5		2,5	20	20	18	20	50	125	2	●	●	
ALG-2R-D20.0R3.2		3,2	20	20	18	20	50	125	2	●	●	
ALG-2R-D20.0R4.0		4	20	20	18	20	50	125	2	●	●	
ALG-2R-D20.0R6.3		6,3	20	20	18	20	50	125	2	○	○	
ALG-2R-D25.0R6.3		6,3	25	25	23	25	75	150	2	○	○	

● Ex stock ○ On demand

* With internal cooling

Milling

C

Drilling

D

Technical Information

E

Index

Application field

P	M	K	N	S	H
			✓		

✓ Very suitable

✓ Suitable

End mill

General machining of Al and Al alloys

ALG-2R-W

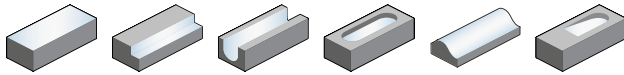

- Factory standard
- Centre cutting
- Helix angle 30°

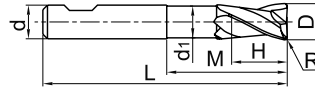

Article	*	Dimensions [mm]							Teeth	Grade
		R	D	d (h6)	d ₁	H	M	L		KMD401
ALG-2R-D6.0R0.3-W		0,3	6	6	5,7	8	16	75	2	●
ALG-2R-D6.0R0.5-W		0,5	6	6	5,7	8	16	75	2	●
ALG-2R-D6.0R1.0-W		1	6	6	5,7	8	16	75	2	●
ALG-2R-D8.0R0.3-W		0,3	8	8	7,4	10	20	75	2	●
ALG-2R-D8.0R0.5-W		0,5	8	8	7,4	10	20	75	2	●
ALG-2R-D8.0R1.0-W		1	8	8	7,4	10	20	75	2	●
ALG-2R-D10.0R0.5-W		0,5	10	10	9,4	12	35	100	2	●
ALG-2R-D10.0R1.0-W		1	10	10	9,4	12	35	100	2	●
ALG-2R-D10.0R1.6-W		1,6	10	10	9,4	12	35	100	2	●
ALG-2R-D10.0R2.5-W		2,5	10	10	9,4	12	35	100	2	●
ALG-2R-D12.0R0.5-W		0,5	12	12	11,4	15	35	100	2	●
ALG-2R-D12.0R1.0-W		1	12	12	11,4	15	35	100	2	●
ALG-2R-D12.0R1.6-W		1,6	12	12	11,4	15	35	100	2	●
ALG-2R-D12.0R2.5-W		2,5	12	12	11,4	15	35	100	2	●
ALG-2R-D12.0R3.2-W		3,2	12	12	11,4	15	35	100	2	●
ALG-2R-D12.0R4.0-W		4	12	12	11,4	15	35	100	2	●
ALG-2R-D16.0R1.0-W		1	16	16	15,4	15	45	125	2	●
ALG-2R-D16.0R1.6-W		1,6	16	16	15,4	15	45	125	2	●
ALG-2R-D16.0R2.5-W		2,5	16	16	15,4	15	45	125	2	●
ALG-2R-D16.0R3.2-W		3,2	16	16	15,4	15	45	125	2	●
ALG-2R-D16.0R4.0-W		4	16	16	15,4	15	45	125	2	●
ALG-2R-D16.0R6.3-W		6,3	16	16	15,4	15	45	125	2	○
ALG-2R-D20.0R1.0-W		1	20	20	18	20	50	125	2	●
ALG-2R-D20.0R1.6-W		1,6	20	20	18	20	50	125	2	●
ALG-2R-D20.0R2.5-W		2,5	20	20	18	20	50	125	2	●
ALG-2R-D20.0R3.2-W		3,2	20	20	18	20	50	125	2	●
ALG-2R-D20.0R4.0-W		4	20	20	18	20	50	125	2	●
ALG-2R-D20.0R6.3-W		6,3	20	20	18	20	50	125	2	○
ALG-2R-D25.0R6.3-W		6,3	25	25	23	25	75	150	2	○

● Ex stock ○ On demand

* With internal cooling

Application field

P	M	K	N	S	H
			✓		

✓ Very suitable

✓ Suitable

A

Turning

B

Milling

C

Drilling

D

Technical Information

E

Index

A

End mill General machining of Al and Al alloys

ALP-3E

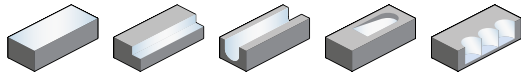

- Factory standard
- Centre cutting
- Helix angle 35°

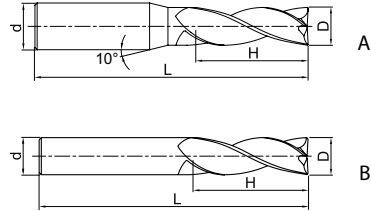

Turning

B

Milling

C

Drilling

D

Technical Information

E

Index

Article	*	Dimensions [mm]				Teeth	Geometry	Grade	
		D	d (h6)	H	L			KMD401	YK40F
ALP-3E-D1.0		1	4	3	50	3	A	○	○
ALP-3E-D1.5		1,5	4	4	50	3	A	○	●
ALP-3E-D2.0		2	4	6	50	3	A	○	●
ALP-3E-D2.5		2,5	4	8	50	3	A	○	○
ALP-3E-D3.0S		3	4	8	50	3	A	○	●
ALP-3E-D4.0S		4	4	11	50	3	B	○	●
ALP-3E-D3.0		3	6	8	50	3	A	●	●
ALP-3E-D4.0		4	6	11	50	3	A	●	●
ALP-3E-D4.5		4,5	6	11	50	3	A	●	○
ALP-3E-D5.0		5	6	13	50	3	A	●	●
ALP-3E-D5.5		5,5	6	16	50	3	A	●	○
ALP-3E-D6.0		6	6	16	50	3	B	●	●
ALP-3E-D7.0		7	8	20	60	3	B	●	○
ALP-3E-D8.0		8	8	20	60	3	B	●	●
ALP-3E-D9.0		9	10	22	75	3	B	●	○
ALP-3E-D10.0		10	10	25	75	3	B	●	●
ALP-3E-D11.0		11	12	26	75	3	B	●	●
ALP-3E-D12.0		12	12	30	75	3	B	●	●
ALP-3E-D14.0		14	14	32	75	3	B	●	●
ALP-3E-D16.0		16	16	45	100	3	B	●	●
ALP-3E-D20.0		20	20	45	100	3	B	●	○

● Ex stock ○ On demand

* With internal cooling

Application field

P	M	K	N	S	H
			✓		

✓ Very suitable

✓ Suitable

End mill **General machining of Al and Al alloys**

ALP-3E-W

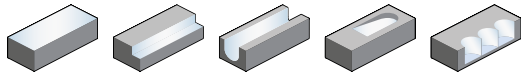

- Factory standard
- Centre cutting
- Helix angle 35°

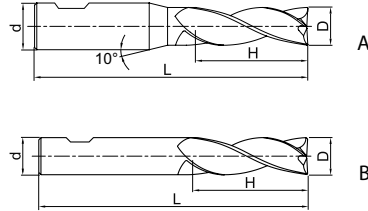

Article	*	Dimensions [mm]				Teeth	Geometry	Grade
		D	d (h6)	H	L			KMD401
ALP-3E-D3.0-W		3	6	8	50	3	A	●
ALP-3E-D4.0-W		4	6	11	50	3	A	●
ALP-3E-D4.5-W		4,5	6	11	50	3	A	●
ALP-3E-D5.0-W		5	6	13	50	3	A	●
ALP-3E-D5.5-W		5,5	6	16	50	3	A	●
ALP-3E-D6.0-W		6	6	16	50	3	B	●
ALP-3E-D7.0-W		7	8	20	60	3	B	●
ALP-3E-D8.0-W		8	8	20	60	3	B	●
ALP-3E-D9.0-W		9	10	22	75	3	B	●
ALP-3E-D10.0-W		10	10	25	75	3	B	●
ALP-3E-D11.0-W		11	12	26	75	3	B	●
ALP-3E-D12.0-W		12	12	30	75	3	B	●
ALP-3E-D14.0-W		14	14	32	75	3	B	●
ALP-3E-D16.0-W		16	16	45	100	3	B	●
ALP-3E-D20.0-W		20	20	45	100	3	B	●

● Ex stock ○ On demand

* With internal cooling

Application field					
P	M	K	N	S	H
			✓		

- ✓ Very suitable
- ✓ Suitable

A

Turning

B

Milling

C

Drilling

D

Technical Information

E

Index

A

End mill General machining of Al and Al alloys

ALP-4E

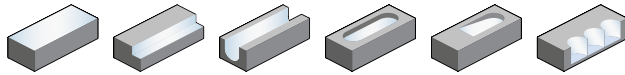

- Factory standard
- Centre cutting
- Helix angle 38°

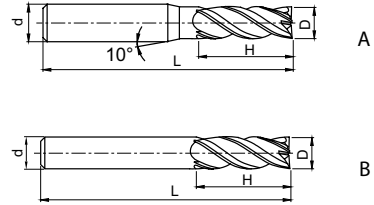

Turning

B

Milling

Article	*	Dimensions [mm]				Teeth	Geometry	Grade	
		D	d (h6)	H	L			KMD401	YK40F
ALP-4E-D3.0S		3	4	9	50	4	A	○	●
ALP-4E-D4.0S		4	4	11	50	4	B	○	●
ALP-4E-D3.0		3	6	9	50	4	A	●	●
ALP-4E-D4.0		4	6	11	50	4	A	●	●
ALP-4E-D5.0		5	6	13	50	4	A	●	●
ALP-4E-D6.0		6	6	16	50	4	B	●	●
ALP-4E-D8.0		8	8	20	60	4	B	●	●
ALP-4E-D10.0		10	10	25	75	4	B	●	●
ALP-4E-D12.0		12	12	30	75	4	B	●	●
ALP-4E-D16.0		16	16	45	100	4	B	●	●
ALP-4E-D18.0		18	18	45	100	4	B	●	○
ALP-4E-D20.0		20	20	45	100	4	B	●	●

● Ex stock ○ On demand

* With internal cooling

C

Drilling

D

Technical Information

Application field

P	M	K	N	S	H
			✓		

✓ Very suitable

✓ Suitable

E

Index

End mill

General machining of Al and Al alloys

ALP-4E-W

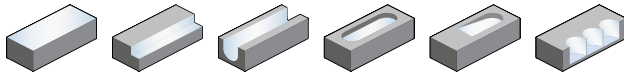

- Factory standard
- Centre cutting
- Helix angle 38°

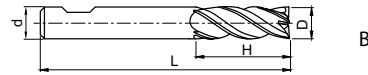
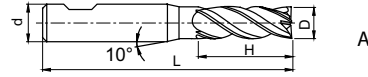

Article	*	Dimensions [mm]				Teeth	Geometry	Grade
		D	d (h6)	H	L			KMD401
ALP-4E-D3.0-W		3	6	9	50	4	A	●
ALP-4E-D4.0-W		4	6	11	50	4	A	●
ALP-4E-D5.0-W		5	6	13	50	4	A	●
ALP-4E-D6.0-W		6	6	16	50	4	B	●
ALP-4E-D8.0-W		8	8	20	60	4	B	●
ALP-4E-D10.0-W		10	10	25	75	4	B	●
ALP-4E-D12.0-W		12	12	30	75	4	B	●
ALP-4E-D16.0-W		16	16	45	100	4	B	●
ALP-4E-D18.0-W		18	18	45	100	4	B	●
ALP-4E-D20.0-W		20	20	45	100	4	B	●

● Ex stock ○ On demand

* With internal cooling

Application field

P	M	K	N	S	H
			✓		

✓ Very suitable

✓ Suitable

A

Turning

B

Milling

C

Drilling

D

Technical
Information

E

Index

End mill – AL series, ALP/ALG series

	Material group	Composition / structure / heat treatment	Brinell hardness HB	Machining group	Starting values for cutting speed v_c [m/min]									
					ALP-1EP				AL-1E AL-2E AL-3E (W) ALG-2E					
					Slot milling		Shoulder milling		Slot milling		Shoulder milling			
					\varnothing [mm]	a_{pmax}	\varnothing [mm]	$a_{e max}$	\varnothing [mm]	$a_{p max}$	\varnothing [mm]	$a_{e max}$		
					$0 < x < 6$	$1 \times D$	$0 < x \leq 12$	$< 1 \times D$	$0 < x < 12$	$0.5 \times D$	$0 < x \leq 20$	$< 0.5 \times D$		
					$6 \leq x \leq 12$	$1.5 \times D$			$12 \leq x \leq 20$	$1.0 \times D$				
					YK40F / KMD401				YK30F / YK40F					
					1/1		1/2		1/10		f-group			
P	Unalloyed steel	approx. 0,15 % C	annealed	125	1									
		approx. 0,45 % C	annealed	190	2									
		approx. 0,45 % C	tempered	250	3									
		approx. 0,75 % C	annealed	270	4									
		approx. 0,75 % C	tempered	300	5									
P	Low-alloyed steel		annealed	180	6									
			tempered	275	7									
			tempered	300	8									
			tempered	350	9									
P	High-alloyed steel and high-alloyed tool steel		annealed	200	10									
			hardened and tempered	325	11									
M	Stainless steel	ferritic/martensitic	annealed	200	12									
			tempered	240	13									
		austenitic	quench hardened	180	14									
				230	15									
K	Grey cast iron	perlitic/ferritic		180	16									
		perlitic (martensitic)		260	17									
K	Cast iron with spheroidal graphite	ferritic		160	18									
		perlitic		250	19									
K	Malleable cast iron	ferritic		130	20									
		perlitic		230	21									
N	Aluminium wrought alloys	cannot be hardened		60	22	300	345	375	12	920	1100	1200	4	
		hardenable	hardened	100	23	250	290	315	12	555	660	720	4	
	Cast aluminium alloys	$\leq 12\% \text{ Si}$, cannot be hardened		75	24	250	280	315	12	370	440	480	4	
		$\leq 12\% \text{ Si}$, hardenable	hardened	90	25	210	240	265	12	460	550	600	4	
		$> 12\% \text{ Si}$, cannot be hardened		130	26	180	210	225	12	140	165	180	4	
Copper and copper alloys (bronze/brass)	machining steel, PB > 1%			110	27	280	320	350	12	280	330	360	4	
	CuZn, CuSnZn			90	28	310	360	390	12	325	385	420	4	
	CuSn, Pb-free copper, electrolytic copper			100	29	280	320	350	12	280	330	360	4	
S	Heat-resistant alloys	Fe-based alloys	annealed	200	30									
			hardened	280	31									
		Ni or Co bass	annealed	250	32									
			hardened	350	33									
	Titanium alloys		cast	320	34									
pure titanium			R_m 400	35										
	α and β alloys	hardened	R_m 1050	36										
H	Hardened steel		hardened and tempered	55 HRC	37									
			hardened and tempered	60 HRC	38									
H	Hard cast iron		cast	400	39									
H	Hardened cast iron		hardened and tempered	55 HRC	40									
X	Non-metallic materials	Thermoplasts			41									
		Thermosetting plastics			42									
		Plastic, glass-fibre reinforced GFRP			43									
		Plastic, carbon fibre reinforced CFRP			44									
		Graphite			45									
		Wood			46									

Note: The given cutting values are guide values, which were determined under ideal conditions.
 The values have to be adapted in individual cases.
 Feed rate recommendations on page B460.
 For examples of material for cutting tool groups view page D22.

A

Recommended feed rate

Solid carbide milling group 8 – High feed mills AL series, ALP/ALG series

	a_e / D	Feed rate per cutting edge (f_z) [mm]																	
		Ø 6	Ø 8	Ø 10	Ø 12	Ø 14	Ø 16	Ø 18	Ø 20										
N	1/1	0,04	0,05	0,08	0,09	0,11	0,13	0,16	0,18										
	3/4	0,05	0,07	0,10	0,12	0,14	0,16	0,20	0,23										
	1/10	0,08	0,11	0,16	0,19	0,22	0,25	0,31	0,36										

Note: The given cutting values are guide values, which were determined under ideal conditions.
The values have to be adapted in individual cases.

Turning

B

Solid carbide milling group 12 – ALP-1EP single-edged cutters

	a_e / D	Feed rate per cutting edge (f_z) [mm]																	
		Ø 2	Ø 3	Ø 4	Ø 5	Ø 6	Ø 8	Ø 10											
N	1/1	0,03	0,05	0,07	0,09	0,11	0,14	0,18											
	1/2	0,04	0,07	0,10	0,13	0,15	0,20	0,25											
	1/10	0,06	0,11	0,15	0,19	0,23	0,29	0,38											

Note: The given cutting values are guide values, which were determined under ideal conditions.
The values have to be adapted in individual cases.

Milling

C

Drilling

D

Technical Information

E

Index

Solid carbide drilling

System code – solid carbide drills

C62–C63

GD series for high feeds

C65–C75

C

A

Turning

B

Milling

C

Drilling

D

Technical
Information

E

Index

1 5 3 6 SU 05 (C) – 0850 (S)

1

2

3

4

5

6

7

8

9

A

Turning

Type	
Code	Description
1	Forets

1

Shank type	
Code	Description
1	Straight shank
2	Square shank DIN 10
3	Double flattened straight shank DIN 1809
5	Straight shank DIN 6535 HA
6	Weldon shank DIN 6535 HB
7	Whistle Notch shank DIN 6535 HE
9	Morse taper shank

2

B

Milling

Drill type	
Code	Description
0	Twist drill
3	Universal twist drill
4	NC tapping device
5	Step drill
6	Three-lips drill
7	Straight flute drill
8	Deep hole drill

3

Tool length	
Code	Description
1	DIN 338
2	DIN 1897
3	QJ/ZZQ(TO)01.001.002
4	DIN 6537 K
5	DIN 6539
6	DIN 6537 L
7	Factory standard ZCC-C
8	Factory standard ZCC-D
9	Factory standard ZCC-E

4

C

Drilling

Application	
Code	Description
UD	Twist drills for tough materials
GD	Twist drills for high feeds
SU	Twist drill for general machining
SUK	Twist drill for cast iron
SL	Twist drill for deep hole drilling
SLK	Deep hole drill for cast iron
SP	Pilot drill
ST	Twist drill for soft steel and stainless steel
SH	Twist drill for hardened materials
SC	Twist drill for non-ferrous metals and cast iron
PA	Three-lips drill for non-ferrous metals and cast iron
PC	Straight flute drill for non-ferrous metals and cast iron

5

D

Technical Information

E

Index

L/D relation		Angle	
Drill		NC tapping device	
Code	Description	Code	Description
03	3xD	90	90°
05	5xD	120	120°
08	8xD		
10	10xD		
12	12xD		
15	15xD		
20	20xD		
30	30xD		

With inner cooling

6

7

Bore diameter [mm]	
Code	Description
0200	2,0
0850	8,5
1800	18,0
...	

Shank diameter [mm]	
Code	Description
S	4,0

8

9

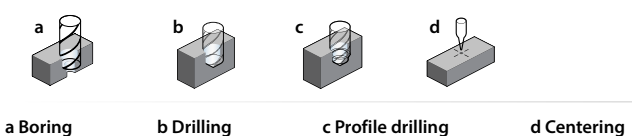

Notes

A

Turning

B

Milling

C

Drilling

D

Technical
Information

E

Index

Lined area for notes, containing horizontal dotted lines for writing.

GD series

Solid carbide drills for high feeds



1536GD05C



Expanded product line: now also available in 3xD and with Weldon surface

- For machining of steel and cast iron materials
- 4 guide chamfer design offers increased stability at high feed rates
- Special chip flute design allows a significantly increased metal removed rate
- Multi-layer PVD coating with low risk of cracking and increased thermal stability
- Up to 2.5 higher productivity due to high feed rates at low cutting speeds
- Diameter range 3.0–20.0 mm (5xD)

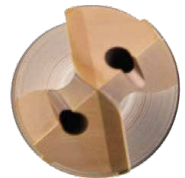

Straight cut

New grade KDG304:

- PVD coated carbide substrate for machining cast steel and cast iron
- Optimised toughness for high feeds

Feed calculator

ISO group	Material	Cutting speed v_c (m/min)	Feed factor* F_m
P	Low-alloy steel	130	0,04
	High-alloy steel	100	0,03
K	Cast iron	160	0,04
	Cast steel	130	0,03

Formula: feed per revolution (F_n) $D \times F_m$
 Example: drill diameter (D) 10 mm
 material high-alloy steel

$$F_n = 10 \text{ mm} \times 0,03 = 0,3 \text{ mm/r}$$

*The stated values are maximum values. For unstable clamping set-ups or low-powered machines, we recommend reducing the feed by around 30% for a drill diameter of $\varnothing 12$ mm or greater.

Solid carbide drills GD series

A

GD drill 5xD

Steel, cast iron

Turning

1534GD03C



- Shank type: DIN 6535HA
- Coolant exit, axial concentric



Internal coolant

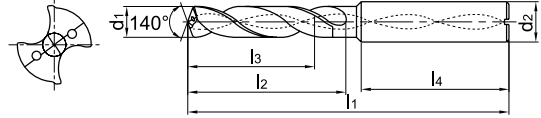

B

Milling

Article	*	Dimensions [mm]						Grade
		d ₁ (m7)	d ₂ (h6)	l ₁	l ₂	l ₃	l ₄	KDG304
1534GD03C-0300	*	3	6	62	20	14	36	●
1534GD03C-0310	*	3,1	6	62	20	14	36	●
1534GD03C-0320	*	3,2	6	62	20	14	36	●
1534GD03C-0330	*	3,3	6	62	20	14	36	●
1534GD03C-0340	*	3,4	6	62	20	14	36	●
1534GD03C-0350	*	3,5	6	62	20	14	36	●
1534GD03C-0360	*	3,6	6	62	20	14	36	●
1534GD03C-0370	*	3,7	6	62	20	14	36	●
1534GD03C-0380	*	3,8	6	66	24	17	36	●
1534GD03C-0390	*	3,9	6	66	24	17	36	●
1534GD03C-0400	*	4	6	66	24	17	36	●
1534GD03C-0410	*	4,1	6	66	24	17	36	●
1534GD03C-0420	*	4,2	6	66	24	17	36	●
1534GD03C-0430	*	4,3	6	66	24	17	36	●
1534GD03C-0440	*	4,4	6	66	24	17	36	●
1534GD03C-0450	*	4,5	6	66	24	17	36	●
1534GD03C-0460	*	4,6	6	66	24	17	36	●
1534GD03C-0465	*	4,65	6	66	24	17	36	●
1534GD03C-0470	*	4,7	6	66	24	17	36	●
1534GD03C-0480	*	4,8	6	66	28	20	36	●
1534GD03C-0490	*	4,9	6	66	28	20	36	●
1534GD03C-0500	*	5	6	66	28	20	36	●
1534GD03C-0510	*	5,1	6	66	28	20	36	●
1534GD03C-0520	*	5,2	6	66	28	20	36	●
1534GD03C-0530	*	5,3	6	66	28	20	36	●
1534GD03C-0540	*	5,4	6	66	28	20	36	●
1534GD03C-0550	*	5,5	6	66	28	20	36	●
1534GD03C-0560	*	5,6	6	66	28	20	36	●
1534GD03C-0570	*	5,7	6	66	28	20	36	●
1534GD03C-0580	*	5,8	6	66	28	20	36	●
1534GD03C-0590	*	5,9	6	66	28	20	36	●
1534GD03C-0600	*	6	6	66	28	20	36	●
1534GD03C-0610	*	6,1	8	79	34	24	36	●
1534GD03C-0620	*	6,2	8	79	34	24	36	●
1534GD03C-0630	*	6,3	8	79	34	24	36	●

● Ex stock ○ On demand

* With internal cooling

C

Drilling

D

Technical Information

E

Index

Application field

Type	P	M	K	N	S	H
1534GD*	✓		✓			

✓ Very suitable

✓ Suitable

GD drill 5xD

Steel, cast iron

1534GD03C



- Shank type: DIN 6535HA
- Coolant exit, axial concentric



Internal coolant

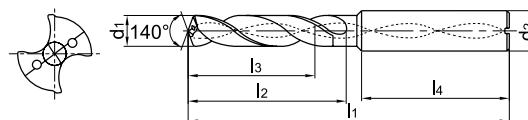

Article	*	Dimensions [mm]						Grade
		d ₁ (m7)	d ₂ (h6)	l ₁	l ₂	l ₃	l ₄	KDG304
1534GD03C-0640	*	6,4	8	79	34	24	36	●
1534GD03C-0650	*	6,5	8	79	34	24	36	●
1534GD03C-0660	*	6,6	8	79	34	24	36	●
1534GD03C-0670	*	6,7	8	79	34	24	36	●
1534GD03C-0680	*	6,8	8	79	34	24	36	●
1534GD03C-0690	*	6,9	8	79	34	24	36	●
1534GD03C-0700	*	7	8	79	34	24	36	●
1534GD03C-0710	*	7,1	8	79	41	29	36	●
1534GD03C-0720	*	7,2	8	79	41	29	36	●
1534GD03C-0730	*	7,3	8	79	41	29	36	●
1534GD03C-0740	*	7,4	8	79	41	29	36	●
1534GD03C-0750	*	7,5	8	79	41	29	36	●
1534GD03C-0760	*	7,6	8	79	41	29	36	●
1534GD03C-0770	*	7,7	8	79	41	29	36	●
1534GD03C-0780	*	7,8	8	79	41	29	36	●
1534GD03C-0790	*	7,9	8	79	41	29	36	●
1534GD03C-0800	*	8	8	79	41	29	36	●
1534GD03C-0810	*	8,1	10	89	47	35	40	●
1534GD03C-0820	*	8,2	10	89	47	35	40	●
1534GD03C-0830	*	8,3	10	89	47	35	40	●
1534GD03C-0840	*	8,4	10	89	47	35	40	●
1534GD03C-0850	*	8,5	10	89	47	35	40	●
1534GD03C-0860	*	8,6	10	89	47	35	40	●
1534GD03C-0870	*	8,7	10	89	47	35	40	●
1534GD03C-0880	*	8,8	10	89	47	35	40	●
1534GD03C-0890	*	8,9	10	89	47	35	40	●
1534GD03C-0900	*	9	10	89	47	35	40	●
1534GD03C-0910	*	9,1	10	89	47	35	40	●
1534GD03C-0920	*	9,2	10	89	47	35	40	●
1534GD03C-0930	*	9,3	10	89	47	35	40	●
1534GD03C-0940	*	9,4	10	89	47	35	40	●
1534GD03C-0950	*	9,5	10	89	47	35	40	●
1534GD03C-0960	*	9,6	10	89	47	35	40	●
1534GD03C-0970	*	9,7	10	89	47	35	40	●
1534GD03C-0980	*	9,8	10	89	47	35	40	●

● Ex stock ○ On demand

* With internal cooling

Application field						
Type	P	M	K	N	S	H
1534GD*	✓		✓			

- ✓ Very suitable
- ✓ Suitable

A

GD drill 5xD

Steel, cast iron

Turning

1534GD03C



- Shank type: DIN 6535HA
- Coolant exit, axial concentric



Internal coolant

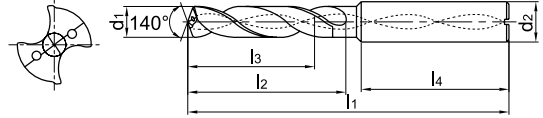

B

Milling

Article	*	Dimensions [mm]						Grade
		d ₁ (m7)	d ₂ (h6)	l ₁	l ₂	l ₃	l ₄	KDG304
1534GD03C-0990	*	9,9	10	89	47	35	40	●
1534GD03C-1000	*	10	10	89	47	35	40	●
1534GD03C-1020	*	10,2	12	102	55	40	45	●
1534GD03C-1050	*	10,5	12	102	55	40	45	●
1534GD03C-1100	*	11	12	102	55	40	45	●
1534GD03C-1140	*	11,4	12	102	55	40	45	●
1534GD03C-1150	*	11,5	12	102	55	40	45	●
1534GD03C-1200	*	12	12	102	55	40	45	●
1534GD03C-1250	*	12,5	14	107	60	43	45	●
1534GD03C-1300	*	13	14	107	60	43	45	●
1534GD03C-1350	*	13,5	14	107	60	43	45	●
1534GD03C-1400	*	14	14	107	60	43	45	●
1534GD03C-1450	*	14,5	16	115	65	45	48	●
1534GD03C-1500	*	15	16	115	65	45	48	●
1534GD03C-1550	*	15,5	16	115	65	45	48	●
1534GD03C-1600	*	16	16	115	65	45	48	●
1534GD03C-1650	*	16,5	18	123	73	51	48	●
1534GD03C-1700	*	17	18	123	73	51	48	●
1534GD03C-1750	*	17,5	18	123	73	51	48	●
1534GD03C-1800	*	18	18	123	73	51	48	●
1534GD03C-1850	*	18,5	20	131	79	55	50	●
1534GD03C-1900	*	19	20	131	79	55	50	●
1534GD03C-1950	*	19,5	20	131	79	55	50	●
1534GD03C-2000	*	20	20	131	79	55	50	●

● Ex stock ○ On demand

* With internal cooling

C

Drilling

D

Technical Information

Application field

Type	P	M	K	N	S	H
1534GD*	✓		✓			

✓ Very suitable

✓ Suitable

E

Index

GD drill 5xD

Steel, cast iron

1536GD05C



- Shank type: DIN 6535HA
- Coolant exit, axial concentric



Internal coolant

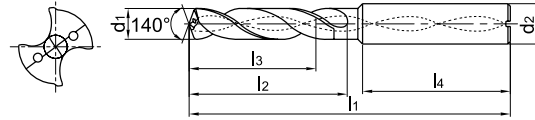

Article	*	Dimensions [mm]						Grade
		d ₁ (m7)	d ₂ (h6)	l ₁	l ₂	l ₃	l ₄	KDG304
1536GD05C-0300	*	3	6	66	28	23	36	●
1536GD05C-0310	*	3,1	6	66	28	23	36	●
1536GD05C-0320	*	3,2	6	66	28	23	36	●
1536GD05C-0330	*	3,3	6	66	28	23	36	●
1536GD05C-0340	*	3,4	6	66	28	23	36	●
1536GD05C-0350	*	3,5	6	66	28	23	36	●
1536GD05C-0360	*	3,6	6	66	28	23	36	●
1536GD05C-0370	*	3,7	6	66	28	23	36	●
1536GD05C-0380	*	3,8	6	74	36	29	36	●
1536GD05C-0390	*	3,9	6	74	36	29	36	●
1536GD05C-0400	*	4	6	74	36	29	36	●
1536GD05C-0410	*	4,1	6	74	36	29	36	●
1536GD05C-0420	*	4,2	6	74	36	29	36	●
1536GD05C-0430	*	4,3	6	74	36	29	36	●
1536GD05C-0440	*	4,4	6	74	36	29	36	●
1536GD05C-0450	*	4,5	6	74	36	29	36	●
1536GD05C-0460	*	4,6	6	74	36	29	36	●
1536GD05C-0465	*	4,65	6	74	36	29	36	●
1536GD05C-0470	*	4,7	6	74	36	29	36	●
1536GD05C-0480	*	4,8	6	82	44	35	36	●
1536GD05C-0490	*	4,9	6	82	44	35	36	●
1536GD05C-0500	*	5	6	82	44	35	36	●
1536GD05C-0510	*	5,1	6	82	44	35	36	●
1536GD05C-0520	*	5,2	6	82	44	35	36	●
1536GD05C-0530	*	5,3	6	82	44	35	36	●
1536GD05C-0540	*	5,4	6	82	44	35	36	●
1536GD05C-0550	*	5,5	6	82	44	35	36	●
1536GD05C-0560	*	5,6	6	82	44	35	36	●
1536GD05C-0570	*	5,7	6	82	44	35	36	●
1536GD05C-0580	*	5,8	6	82	44	35	36	●
1536GD05C-0590	*	5,9	6	82	44	35	36	●
1536GD05C-0600	*	6	6	82	44	35	36	●
1536GD05C-0610	*	6,1	8	91	53	43	36	●
1536GD05C-0620	*	6,2	8	91	53	43	36	●
1536GD05C-0630	*	6,3	8	91	53	43	36	●

● Ex stock ○ On demand

* With internal cooling

Application field						
Type	P	M	K	N	S	H
1536GD*	✓		✓			

- ✓ Very suitable
- ✓ Suitable

A

Turning

B

Milling

C

Drilling

D

Technical Information

E

Index

Solid carbide drills GD series

A

GD drill 5xD

Steel, cast iron

Turning

1536GD05C



- Shank type: DIN 6535HA
- Coolant exit, axial concentric



Internal coolant

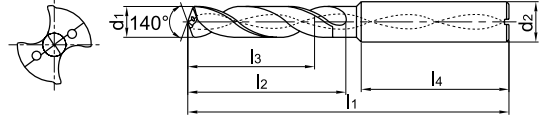

B

Milling

Article	*	Dimensions [mm]						Grade
		d ₁ (m7)	d ₂ (h6)	l ₁	l ₂	l ₃	l ₄	KDG304
1536GD05C-0640	*	6,4	8	91	53	43	36	●
1536GD05C-0650	*	6,5	8	91	53	43	36	●
1536GD05C-0660	*	6,6	8	91	53	43	36	●
1536GD05C-0670	*	6,7	8	91	53	43	36	●
1536GD05C-0680	*	6,8	8	91	53	43	36	●
1536GD05C-0690	*	6,9	8	91	53	43	36	●
1536GD05C-0700	*	7	8	91	53	43	36	●
1536GD05C-0710	*	7,1	8	91	53	43	36	●
1536GD05C-0720	*	7,2	8	91	53	43	36	●
1536GD05C-0730	*	7,3	8	91	53	43	36	●
1536GD05C-0740	*	7,4	8	91	53	43	36	●
1536GD05C-0750	*	7,5	8	91	53	43	36	●
1536GD05C-0760	*	7,6	8	91	53	43	36	●
1536GD05C-0770	*	7,7	8	91	53	43	36	●
1536GD05C-0780	*	7,8	8	91	53	43	36	●
1536GD05C-0790	*	7,9	8	91	53	43	36	●
1536GD05C-0800	*	8	8	91	53	43	36	●
1536GD05C-0810	*	8,1	10	103	61	49	40	●
1536GD05C-0820	*	8,2	10	103	61	49	40	●
1536GD05C-0830	*	8,3	10	103	61	49	40	●
1536GD05C-0840	*	8,4	10	103	61	49	40	●
1536GD05C-0850	*	8,5	10	103	61	49	40	●
1536GD05C-0860	*	8,6	10	103	61	49	40	●
1536GD05C-0870	*	8,7	10	103	61	49	40	●
1536GD05C-0880	*	8,8	10	103	61	49	40	●
1536GD05C-0890	*	8,9	10	103	61	49	40	●
1536GD05C-0900	*	9	10	103	61	49	40	●
1536GD05C-0910	*	9,1	10	103	61	49	40	●
1536GD05C-0920	*	9,2	10	103	61	49	40	●
1536GD05C-0930	*	9,3	10	103	61	49	40	●
1536GD05C-0940	*	9,4	10	103	61	49	40	●
1536GD05C-0950	*	9,5	10	103	61	49	40	●
1536GD05C-0960	*	9,6	10	103	61	49	40	●
1536GD05C-0970	*	9,7	10	103	61	49	40	●
1536GD05C-0980	*	9,8	10	103	61	49	40	●

C

Drilling

D

Technical Information

- Ex stock ○ On demand
- * With internal cooling

E

Index

Application field

Type	P	M	K	N	S	H
1536GD*	✓		✓			

- ✓ Very suitable
- ✓ Suitable

GD drill 5xD

Steel, cast iron

1536GD05C



- Shank type: DIN 6535HA
- Coolant exit, axial concentric



Internal coolant

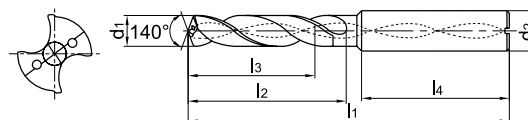

Article	*	Dimensions [mm]						Grade
		d ₁ (m7)	d ₂ (h6)	l ₁	l ₂	l ₃	l ₄	KDG304
1536GD05C-0990	*	9,9	10	103	61	49	40	●
1536GD05C-1000	*	10	10	103	61	49	40	●
1536GD05C-1010	*	10,1	12	118	71	56	45	●
1536GD05C-1020	*	10,2	12	118	71	56	45	●
1536GD05C-1030	*	10,3	12	118	71	56	45	●
1536GD05C-1040	*	10,4	12	118	71	56	45	●
1536GD05C-1050	*	10,5	12	118	71	56	45	●
1536GD05C-1060	*	10,6	12	118	71	56	45	●
1536GD05C-1070	*	10,7	12	118	71	56	45	●
1536GD05C-1080	*	10,8	12	118	71	56	45	●
1536GD05C-1090	*	10,9	12	118	71	56	45	●
1536GD05C-1100	*	11	12	118	71	56	45	●
1536GD05C-1140	*	11,4	12	118	71	56	45	●
1536GD05C-1150	*	11,5	12	118	71	56	45	●
1536GD05C-1200	*	12	12	118	71	56	45	●
1536GD05C-1250	*	12,5	14	124	77	60	45	●
1536GD05C-1300	*	13	14	124	77	60	45	●
1536GD05C-1350	*	13,5	14	124	77	60	45	●
1536GD05C-1400	*	14	14	124	77	60	45	●
1536GD05C-1450	*	14,5	16	133	83	63	48	●
1536GD05C-1500	*	15	16	133	83	63	48	●
1536GD05C-1510	*	15,1	16	133	83	63	48	●
1536GD05C-1550	*	15,5	16	133	83	63	48	●
1536GD05C-1600	*	16	16	133	83	63	48	●
1536GD05C-1650	*	16,5	18	143	93	71	48	●
1536GD05C-1700	*	17	18	143	93	71	48	●
1536GD05C-1750	*	17,5	18	143	93	71	48	●
1536GD05C-1800	*	18	18	143	93	71	48	●
1536GD05C-1850	*	18,5	20	153	101	77	50	●
1536GD05C-1900	*	19	20	153	101	77	50	●
1536GD05C-1950	*	19,5	20	153	101	77	50	●
1536GD05C-2000	*	20	20	153	101	77	50	●

● Ex stock ○ On demand

* With internal cooling

Application field						
Type	P	M	K	N	S	H
1536GD*	✓		✓			

✓ Very suitable
 ✓ Suitable

A

Turning

B

Milling

C

Drilling

D

Technical Information

E

Index

Solid carbide drills GD series

A

GD drill 5xD

Steel, cast iron

New

1636GD05C



- Shank type: DIN 6535HA
- Coolant exit, axial concentric



Internal coolant

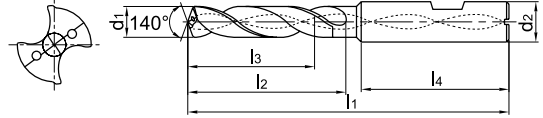

Turning

B

Milling

C

Drilling

D

Technical Information

E

Index

Article	*	Dimensions [mm]						Grade
		d ₁ (m7)	d ₂ (h6)	l ₁	l ₂	l ₃	l ₄	KDG304
1636GD05C-0500	*	5	6	82	44	35	36	●
1636GD05C-0550	*	5,5	6	82	44	35	36	●
1636GD05C-0600	*	6	6	82	44	35	36	●
1636GD05C-0650	*	6,5	8	91	53	43	36	●
1636GD05C-0680	*	6,8	8	91	53	43	36	●
1636GD05C-0700	*	7	8	91	53	43	36	●
1636GD05C-0740	*	7,4	8	91	53	43	36	●
1636GD05C-0750	*	7,5	8	91	53	43	36	●
1636GD05C-0780	*	7,8	8	91	53	43	36	●
1636GD05C-0800	*	8	8	91	53	43	36	●
1636GD05C-0850	*	8,5	10	103	61	49	40	●
1636GD05C-0880	*	8,8	10	103	61	49	40	●
1636GD05C-0900	*	9	10	103	61	49	40	●
1636GD05C-0930	*	9,3	10	103	61	49	40	●
1636GD05C-0950	*	9,5	10	103	61	49	40	●
1636GD05C-0980	*	9,8	10	103	61	49	40	●
1636GD05C-1000	*	10	10	103	61	49	40	●
1636GD05C-1020	*	10,2	12	118	71	56	45	●
1636GD05C-1050	*	10,5	12	118	71	56	45	●
1636GD05C-1080	*	10,8	12	118	71	56	45	●
1636GD05C-1100	*	11	12	118	71	56	45	●
1636GD05C-1150	*	11,5	12	118	71	56	45	●
1636GD05C-1180	*	11,8	12	118	71	56	45	●
1636GD05C-1200	*	12	12	118	71	56	45	●
1636GD05C-1250	*	12,5	14	124	77	60	45	●
1636GD05C-1280	*	12,8	14	124	77	60	45	●
1636GD05C-1300	*	13	14	124	77	60	45	●
1636GD05C-1350	*	13,5	14	124	77	60	45	●
1636GD05C-1380	*	13,8	14	124	77	60	45	●
1636GD05C-1400	*	14	14	124	77	60	45	●
1636GD05C-1450	*	14,5	16	133	83	63	48	●
1636GD05C-1480	*	14,8	16	133	83	63	48	●
1636GD05C-1500	*	15	16	133	83	63	48	●
1636GD05C-1550	*	15,5	16	133	83	63	48	●
1636GD05C-1580	*	15,8	16	133	83	63	48	●

● Ex stock ○ On demand

* With internal cooling

Application field

Type	P	M	K	N	S	H
1636GD*	✓		✓			

✓ Very suitable

✓ Suitable

GD drill 5xD

Steel, cast iron



1636GD05C



- Shank type: DIN 6535HA
- Coolant exit, axial concentric



Internal coolant

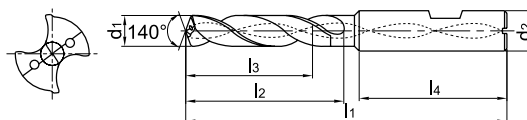

Article	*	Dimensions [mm]						Grade
		d ₁ (m7)	d ₂ (h6)	l ₁	l ₂	l ₃	l ₄	KDG304
1636GD05C-1600	*	16	16	133	83	63	48	●
1636GD05C-1650	*	16,5	18	143	93	71	48	●
1636GD05C-1680	*	16,8	18	143	93	71	48	●
1636GD05C-1700	*	17	18	143	93	71	48	●
1636GD05C-1750	*	17,5	18	143	93	71	48	●
1636GD05C-1780	*	17,8	18	143	93	71	48	●
1636GD05C-1800	*	18	18	143	93	71	48	●
1636GD05C-1850	*	18,5	20	153	101	77	50	●
1636GD05C-1880	*	18,8	20	153	101	77	50	●
1636GD05C-1900	*	19	20	153	101	77	50	●
1636GD05C-1950	*	19,5	20	153	101	77	50	●
1636GD05C-1980	*	19,8	20	153	101	77	50	●
1636GD05C-2000	*	20	20	153	101	77	50	●

● Ex stock ○ On demand

* With internal cooling

Application field						
Type	P	M	K	N	S	H
1636GD*	✓		✓			

✓ Very suitable
 ✓ Suitable

A

Turning

B

Milling

C

Drilling

D

Technical Information

E

Index



Scan for PDF

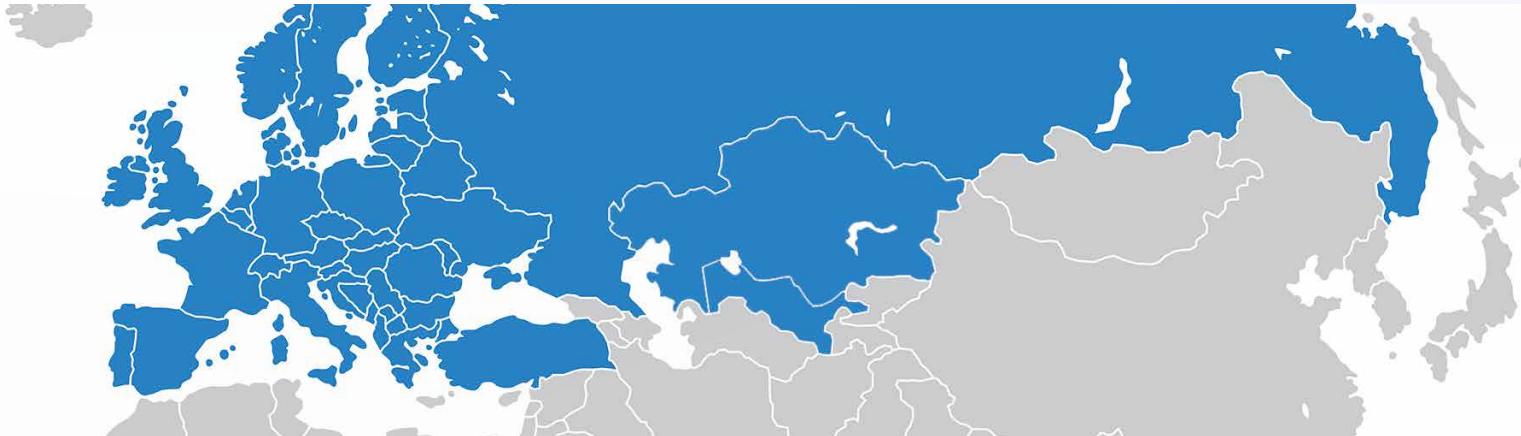

Europe head office

ZCC Cutting Tools Europe GmbH

www.zccct-europe.com

Wanheimer Str. 57, 40472 Düsseldorf, Germany

Tel.: +49 (0) 211-989240-0

Fax: +49 (0) 211-989240-111

E-Mail: info@zccct-europe.com

France branch office

ZCC Cutting Tools Europe GmbH Succursale Française

www.zccct-europe.com

14, Allée Charles Pathé, 18000 Bourges, France

Tel.: +33 (0) 2 45 41 01 40

Fax: +33 (0) 800 74 27 27

E-Mail: ventes@zccct-europe.com

UK branch office

ZCC Cutting Tools Europe GmbH UK Division

www.zccct-europe.com

4200 Waterside Centre, Solihull Parkway

Birmingham Business Park

Birmingham, West Midlands, B37 7YN, UK

Tel.: +44 (0) 121 8095469

Fax: +49 (0) 211-989240-111

E-Mail: infouk@zccct-europe.com

© Copyright by ZCC Cutting Tools Europe GmbH
All rights reserved.

All rights reserved. All descriptions and pictures are protected by copyright. Usage, modification and reproduction, completely or partially, without written permission are prohibited. Subject to technical changes and changes of the delivery program. Mistakes and printing errors are reserved.